



Shakmat Clock O'Pawn Building Guide

Table of contents

1. Preamble	2
2. Components list & necessary tools	3
3. PCB details	4
4. Main PCB assembly	5-8
4.1 Front side	5-6
4.1.1 78L05 IC	5
4.1.2 Jack connectors	5
4.1.3 Small potentiometer	6
4.1.4 Big potentiometer	6
4.2 Back side	7-8
4.2.1 IC socket	7
4.2.2 Small header (2x2 pins)	7
4.2.3 Power header (2x5 pins)	7
4.2.4 Header (1x6 pins)	8
5. Bottom PCB assembly	8-9
5.1 Front side	8-9
5.1.1 15k resistors	8
5.1.2 Push buttons	9
6. Main & bottom PCB assembly	9
7. LED mounting	10-11
8. IC plugging	11
9. Jack & potentiometer nuts	11
10. M3 panel stud nut	12
11. Potentiometer & button caps	12
12. Jumper caps	12
13. Powering & basic testing	13

1. Preamble

Thank you for purchasing a Shakmat DIY kit !

We spare no effort in our kit packing process to prevent any mistakes or missing parts. In this document as well, we try hard to describe the assembly process in the most practical and comprehensive way. If by any chance there is a missing/damaged part in your kit or if you have any suggestion, feel free to contact us via shakmat.com.

We strongly advise you NOT to split all the bags open and mix their components. Some of them are virtually indistinguishable (like LEDs that all appear clear when inactive). We recommend you to only take the necessary component out of it's bag, or to empty the bags in separate & marked containers. For each step, next to the component graphic representation, there is a reference indicating where to find it (i.e. P1 for Pack 1, or LP for Loose Part).

Also, the assembly process will be dramatically simplified if you follow the order defined in this building guide. We tested various orders of steps before finding the most convenient, and the one presented here is the best !

2. Components list & necessary tools

Pack 1

3x Green LEDs
1x Small potentiometer
1x Small header (2x2 pin)
2x Jumper caps
3x Push buttons
2x Small button caps
1x Big button cap
1x 78L05 IC
3x 15k resistors
1x Power header (2x5 pin)
1x Header (1x6 pin)

Pack 2

4x Mono jack connectors
1x Stereo jack connector
2x Amber LEDs
1x Big metal potentiometer
1x Potentiometer nut
5x Jack connector nuts
1x M3 nut (for securing bottom PCB)
2x M3 screws (for rack mounting)

Pack 3

1x Top PCB
1x Bottom PCB

Loose parts

1x Aluminum panel
1x Black rubber knob
1x 2x7 pin ic socket
1x ATtiny
1x Power cable
1x User manual

Necessay tools

Soldering iron
Solder
Cutting pliers
Masking tape

3. PCB details

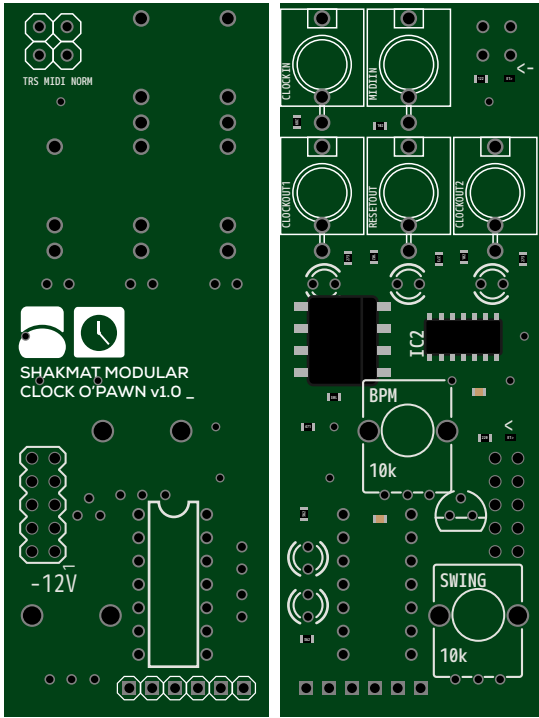

Main PCB
Back & front

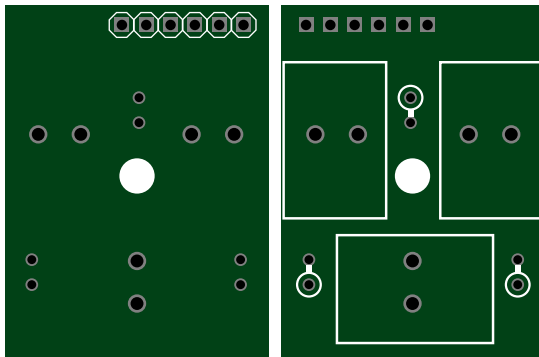

Bottom PCB
Back & front

4. Main PCB assembly

4.1 Front side

4.1.1 78L05 IC

Bend the middle leg of the 78L05 IC. Then place it on the PCB : the flat side has to correspond to the flat side of the silkscreen.



P1

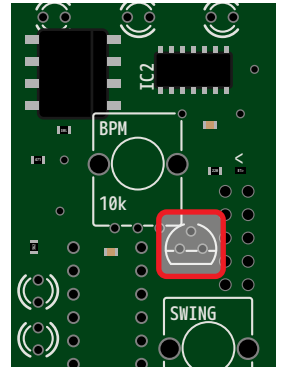

4.1.2.a Mono jack connectors (x4)

There are 5 jack connectors in total. They all have to sit flush with the PCB, so be sure to push them all the way through before soldering. We start with the four mono ones (black).



P2

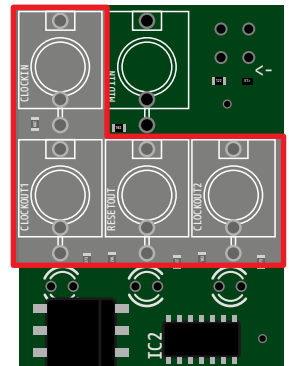

4.1.2.b Stereo jack connector

Solder the last jack connector, the green one. Again it has to sit flush with the PCB, so be sure to push it all the way through before soldering.



P2

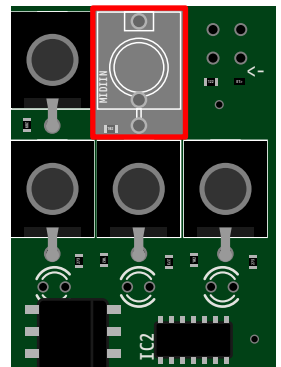

4.1.3 Small potentiometer

Place and solder the potentiometer. Be sure that it's fully pushed inside the PCB holes and that it lays perpendicular to it.

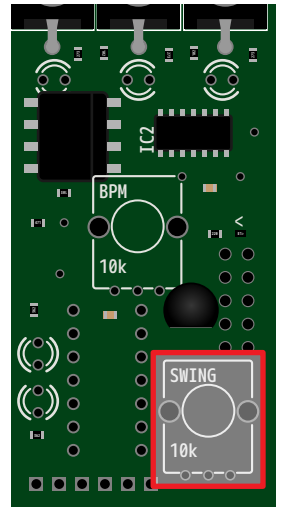
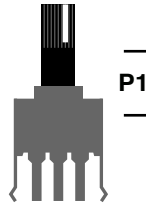

4.1.4 Big potentiometer

Time to mount the big potentiometer. First you'll have to remove a little piece of it as shown in the following picture. Then, you can place and solder it.

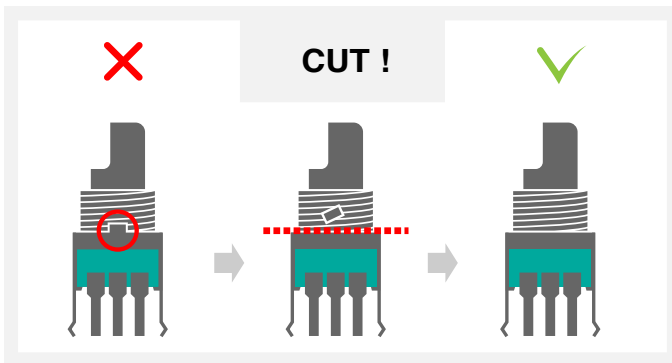
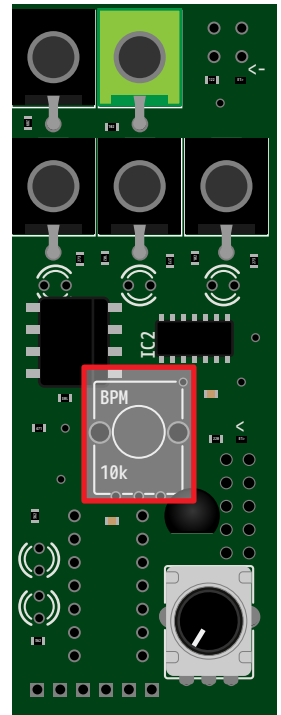
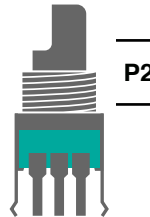

4.2 Back side

4.2.1 IC Socket

Flip the PCB around, we're going to solder the IC socket. Be attentive to it's orientation. The red lines on the magnified picture shows the indentation that has to match the indentation on the PCB silkscreen.

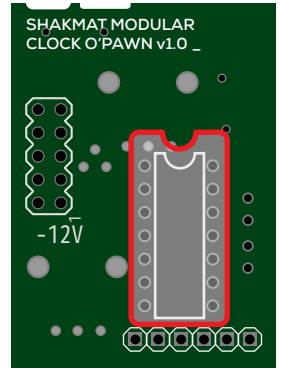
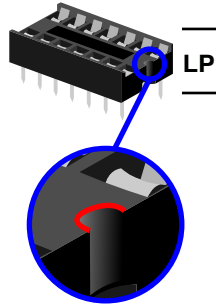

4.2.2 Small header (2x2 pins)

Solder the small 2x2 pin header which will later receive caps for MIDI standard selection. We recommend you to solder only one pin and check the alignment, correct it if necessary, and then solder the remaining pins.

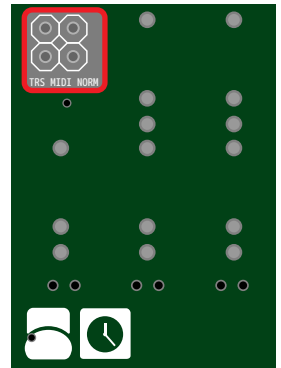

4.2.3 Power header (2x5 pins)

Solder the big 2x5 pin header which is the power connector for the ribbon cable. Be sure to lay it flat on the PCB and solder it perpendicularly. We recommend you to solder only one pin and check the alignment, correct it if necessary, and then solder the remaining pins.

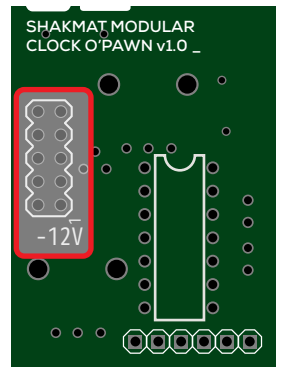
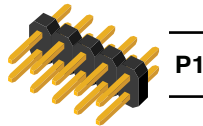

4.2.4 Header (1x6 pins)

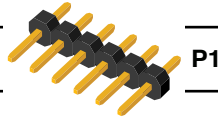

The single row 6 pin header assembles the two PCBs together. For now we are taking care of the short legged side of the header. Be careful with this piece as it has to lay flat on the PCB and perfectly straight. We recommend you to place the header and solder only one leg, then verify the alignment (and correct if necessary) before soldering the remaining legs.

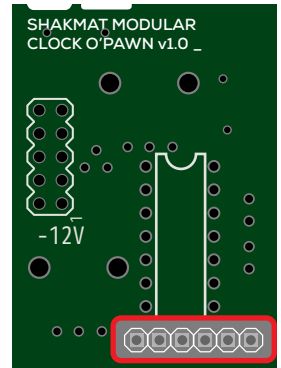

5. Bottom PCB assembly

5.1 Front side

5.1.1 15k resistors (x3)

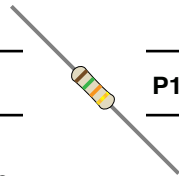

Now, take the smaller PCB and continue. We're going to solder the three 15k resistors. Be attentive to their position. No specific orientation is needed for resistors.

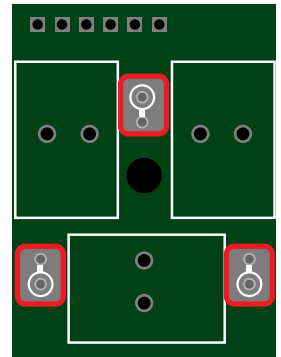

When a resistor is mounted straight up to the PCB, only one of its legs has to be bent. Be careful not to bend the leg to far from the resistor body, this can lead to short-circuits with the aluminum front panel.



5.1.2 Push buttons (x3)

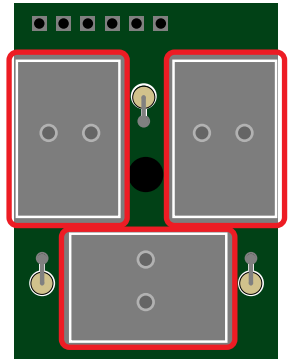
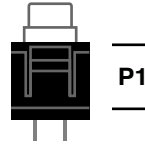

The buttons are easy to place & solder but they need to be thoroughly pushed against the PCB. Before soldering, we recommend to place the four buttons, then flip the PCB and press it against your table in order to ensure that every button is well placed. Be sure to lay them perpendicularly to the PCB.

6. Main & bottom PCB assembly

We will now assemble the two PCBs via the 6 pin header. Be careful that the header you're soldering is well passed through all the PCB holes and that the two PCBs are perfectly horizontal. If there is a gap between the header and the PCBs, or if they're not correctly aligned, the push button could be poorly placed and hard to press. As you did before, we recommend you to only solder one pin of the header and check the alignment before soldering the five other pins.

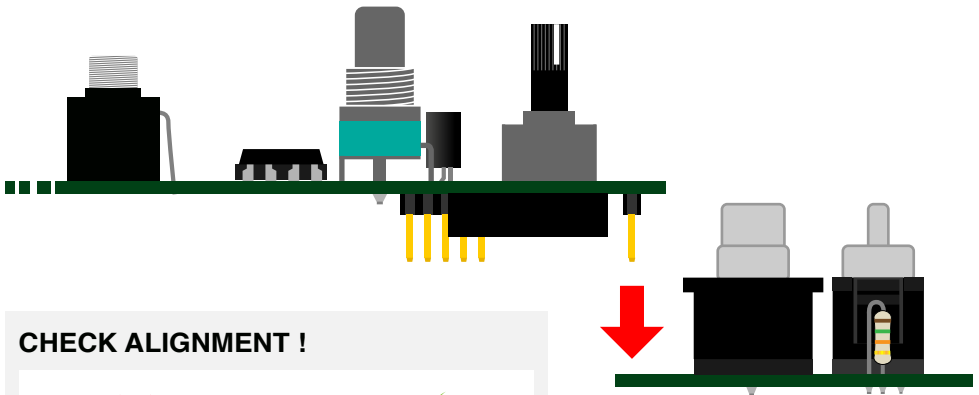

CHECK ALIGNMENT !

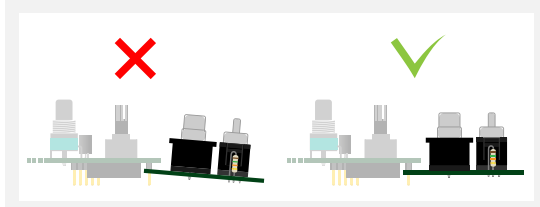

7. LED mounting (1)

Well soldered LEDs are flush with the front panel. For this, you need to assemble front panel & PCBs. We recommend you do this by finger tightening the hex nuts on the BPM potentiometer and some jack sockets.

Be careful with the LED polarity, the long leg is the positive side. Please refer to the following picture to know which LED color goes where. Pay attention not to mix LEDs from different packs, when inactive the clear LEDs are very hard to differentiate from each other.

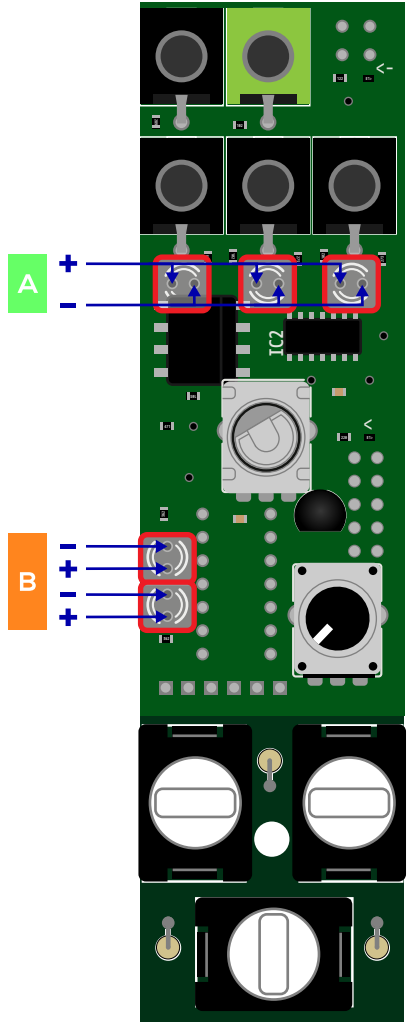
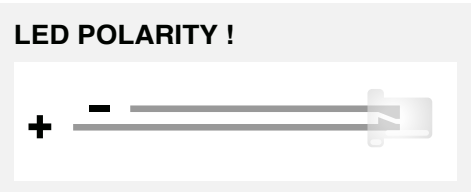
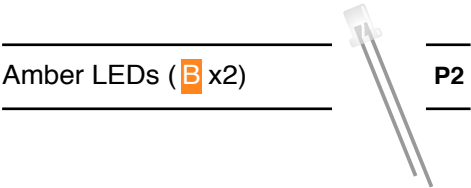
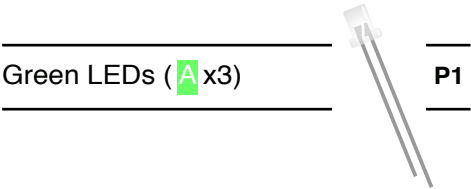

7. LED mounting (2)

A good way to mount the LED neatly is to use masking tape to cover the panel LEDs holes. Therefore you can place them on the PCB, assemble PCBs & panel with some nuts and push the LEDs through the panel until they sit flush and stick to the tape. Finally, you can solder them.

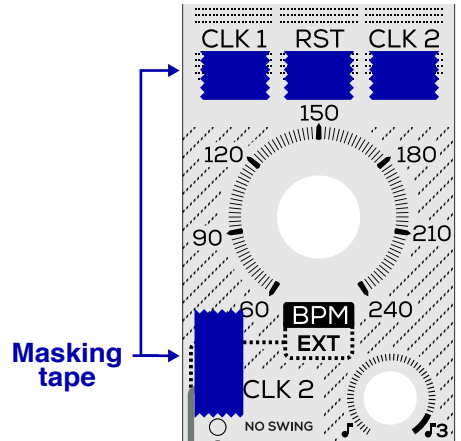

8. IC plugging

Plug the ATtiny IC in the 2x7 IC socket previously soldered. Make sure the indentation on the IC (shown here with the red lines) is matching the indentation on the IC socket.

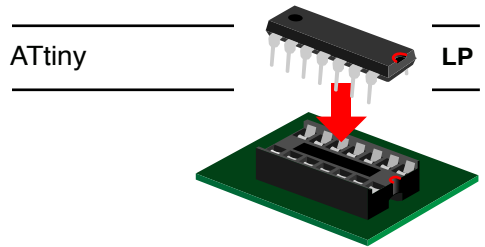

9. Jack & potentiometer nuts

Tighten the knurled nuts on the jack sockets & hex nut on the BPM potentiometer.

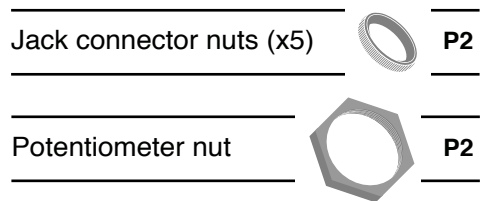

10. M3 panel stud nut

Place the M3 nut on the stud protruding from the bottom PCB on the back side of the panel.

This nut secures the bottom PCB

when the buttons are pressed. To prevent this nut to untighten & fall off over time, we recommend to put a small amount of nail polish on it. Some glue will also do the trick, but can be very problematic to remove if you need to unscrew this nut.

Do not screw the M3 nut to far or it will push the bottom PCB out of it's parallelism with the top PCB and interfere with the button caps. Just tighten it until it sits flush with the bottom PCB.

M3 nut (for Panel stud)



P2

11. Potentiometer & button caps

Mount the three button caps. If somehow they fell a bit loose, you can glue them on the component with some gel glue, just be careful not to let glue drain down the button and destroy it ! Push the knob onto the BPM potentiometer.

Small button caps (x2)



P1

Big button cap

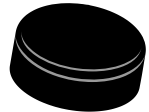

P1

Potentiometer knob



LP

12. Jumper caps

Place the two jumper caps on the previously soldered 2x2 pin header. Placing those horizontally or vertically determines the MIDI standard used. Please refer to the user manual.

Jumper caps (x2)



P1

13. Powering & basic testing

Plug the power cable and make sure the red side of the ribbon matches the -12V on the PCB. Now let's plug the module in your system and test it. The module LEDs don't blink if the module isn't running. So don't panic if the module seems quiet when nothing is connected to it.

To check if the module is working press the big Play/Pause button and mangle with the potentiometer, CLK1 & CLK2 LEDs should be blinking. If not, carefully check every soldering point you've made, especially the IC socket, and make another attempt.

If ever you get trouble or questions, send us an email at support@shakmatmodular.com.

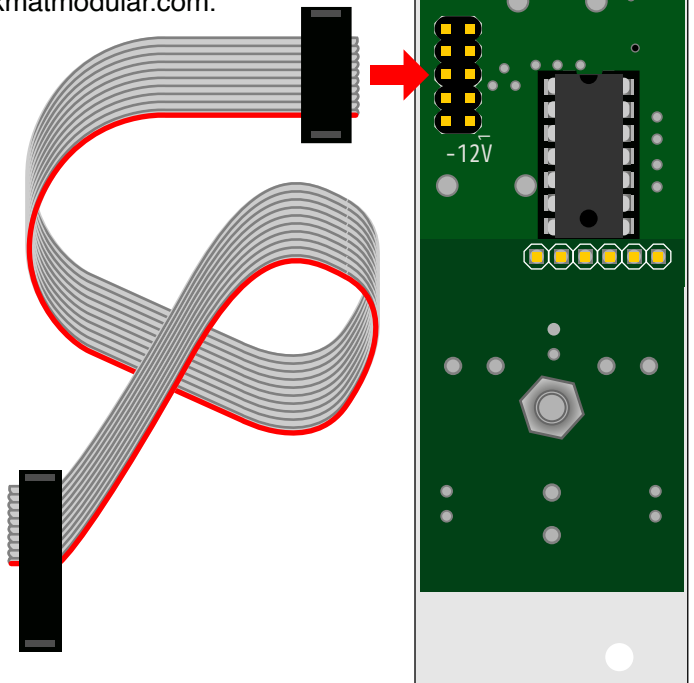

www.shakmat.com ●

 **Shakmat**

Product design & engineering : François Gaspard

Product & brand design : Steve Hackx

Firmware coding : Léonard Steyaert