

Ljunggren Audio

Roll Your Own

Aperture

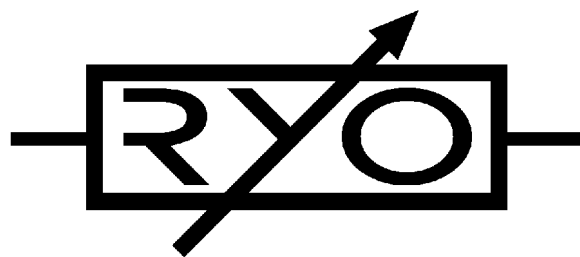

Version: Aperture PCB1: 1.0, PCB2: 1.0 & 1.1

The only difference between PCB2 1.0 & 1.1 is a short missing trace in 1.0 that is very easy to fix and is included in the assembly instructions.

Bills Of Material

Type	Qty	Value	Parts	Description
Power header	1	2x5pin	POWER	Euro power connector
Socket strip	2	1x8pin	CON1-PCB1, CON2-PCB1	
Pin strip	2	1x8pin	CON1-PCB2, CON2-PCB2	
Potentiometer	1	B22K	POT1	9mm vertical mount
Potentiometer	2	B100K	POT2, POT3	9mm vertical mount
Potentiometer	1	A100K	POT4	9mm vertical mount
Jack	4	3.5mm	J1, J2, J3, J4	PJ301M-12 / Thonkiconn / Inline
Toggle switch	1	SPDT on-off-on	SW1	
Toggle switch	1	SPDT on-on	SW2	
LED 3mm	1	orange	D8	
Diode	4	1N4148	D4, D5, D6, D7	General purpose.
Diode	2	1N5818	D1, D2	Schottky rectifier. Power polarity protection. Alternatives: 1N5817, 1N5819, SB130.
3.5mm resistor	1	680K	R16	1% Tolerance
3.5mm resistor	4	68K	R4, R5, R22, R34	1% Tolerance
3.5mm resistor	5	47K	R14, R19, R21, R24, R30	1% Tolerance
3.5mm resistor	1	4.7M	R28	
3.5mm resistor	5	330K	R17, R18, R31, R43, R45	1% Tolerance
3.5mm resistor	3	12K	R13, R15, R25	1% Tolerance
3.5mm resistor	1	0R	R20	Zero ohm/Jumper
3.5mm resistor	5	10K	R3, R27, R29, R40, R44	1% Tolerance
3.5mm resistor	10	100K	R7, R8, R9, R10, R11, R12, R32, R33, R37, R38	1% Tolerance
7mm resistor	1	100R	R23	1/4W
7mm resistor	2	10R	R1, R2	1/4W
7mm resistor	3	1K	R6, R26, R39	1/4W
MLCC X7R	14	100nF	C1, C2, C5, C6, C7, C8, C9, C10, C11, C12, C13, C14, C15, C16	2.5-2.54mm pin pitch
MLCC C0G	1	33nF	C21	2.5-2.54mm pin pitch TDK recommended
MLCC C0G	1	68nF	C19	2.5-2.54mm pin pitch TDK recommended
Electrolytic	4	10uF	C3, C4, C17, C18	2mm pin pitch, 5mm dia, max 10mm height. Min 25V.
Electrolytic	1	2.2uF	C25	2mm pin pitch, 4-5mm dia, max 10mm height. Min 16V.
Film cap	1	220nF	C20	5mm pin pitch WIMA MKS2 recommended
Film cap	1	470nF	C24	5mm pin pitch WIMA MKS2 recommended
Trimmer	3	50K	VR1, VR2, VR3	
Transistor	3	BC547	Q1, Q2, Q3	
Voltage reference	1	LM4040 5V	D3	
IC socket	1	DIP16	IC1	16 pin DIP
Switch IC	1	DG412DJ	IC1	16 pin
IC socket	1	DIP14	IC2	14 pin DIP
OpAmp	1	LM324	IC2	14 pin Alternative: TL064 Alternatives with higher current consumption: TL074, TL084
IC socket	3	DIP8	IC3, IC4, IC5	8 pin DIP
OpAmp	3	TL072	IC3, IC4, IC5	8 pin
Vactrol socket	4	SIP2	LDR1, LDR2	2 pin SIP
Vactrol	2	NSL-32 SR3	LDR1, LDR2	Advanced Photonix/Silonex
Power cable	1	16pin-10pin		
Mounting screws	2	M3x6 black		
Frontplate	1	2mm black		PCB material
PCB1	1			
PCB2	1			
spacers	2	11mm		
nuts	2	for spacers		
screws	2	for spacers		
Knob	3	small cream		
Knob	1	big red		

Assembly instructions

We start with PCB2.

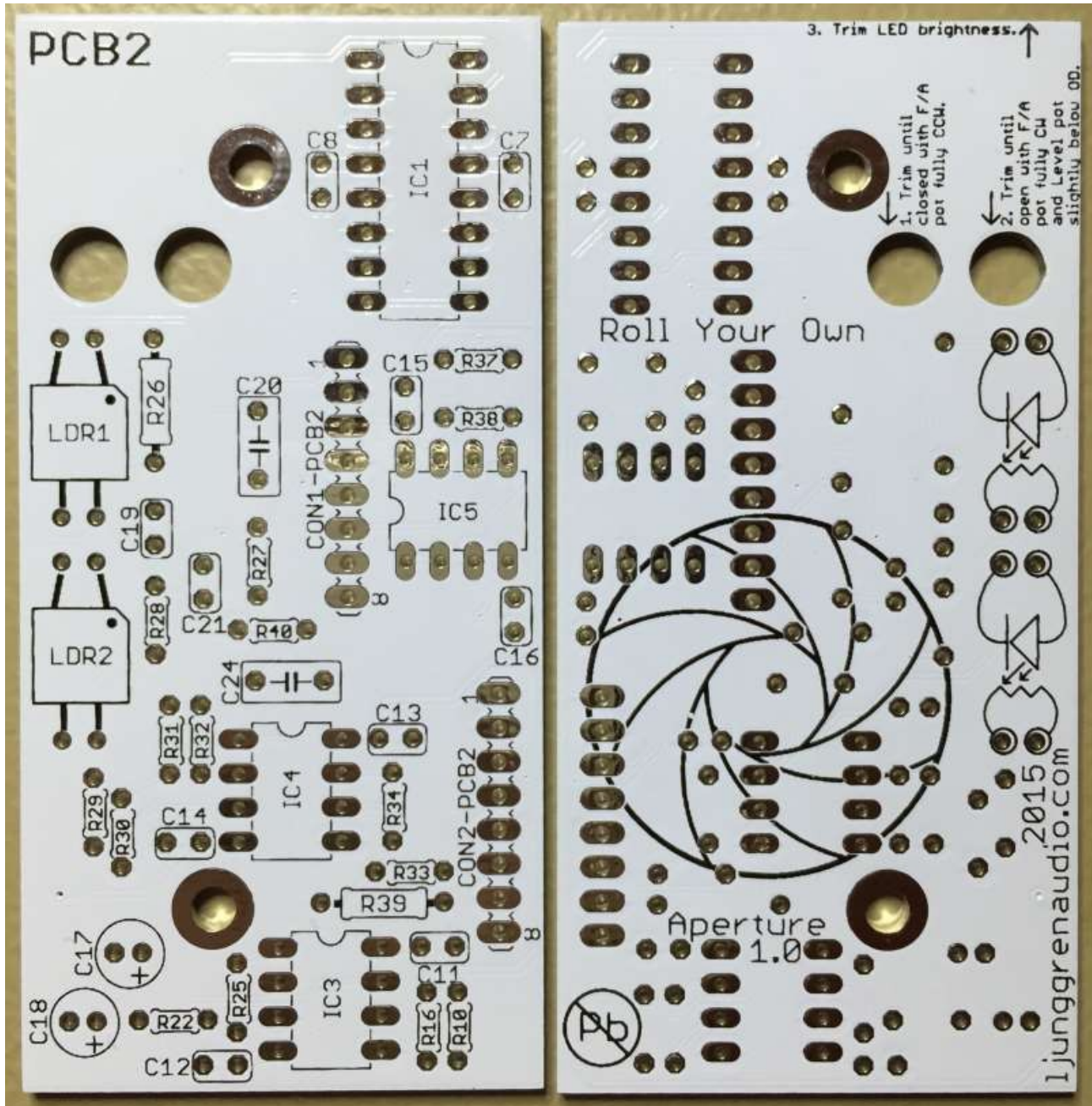

Empty PCB2 top & bottom.

Step 1

Solder small (ca 3.5mm) resistors. Resistors are not sensitive to mounting direction.

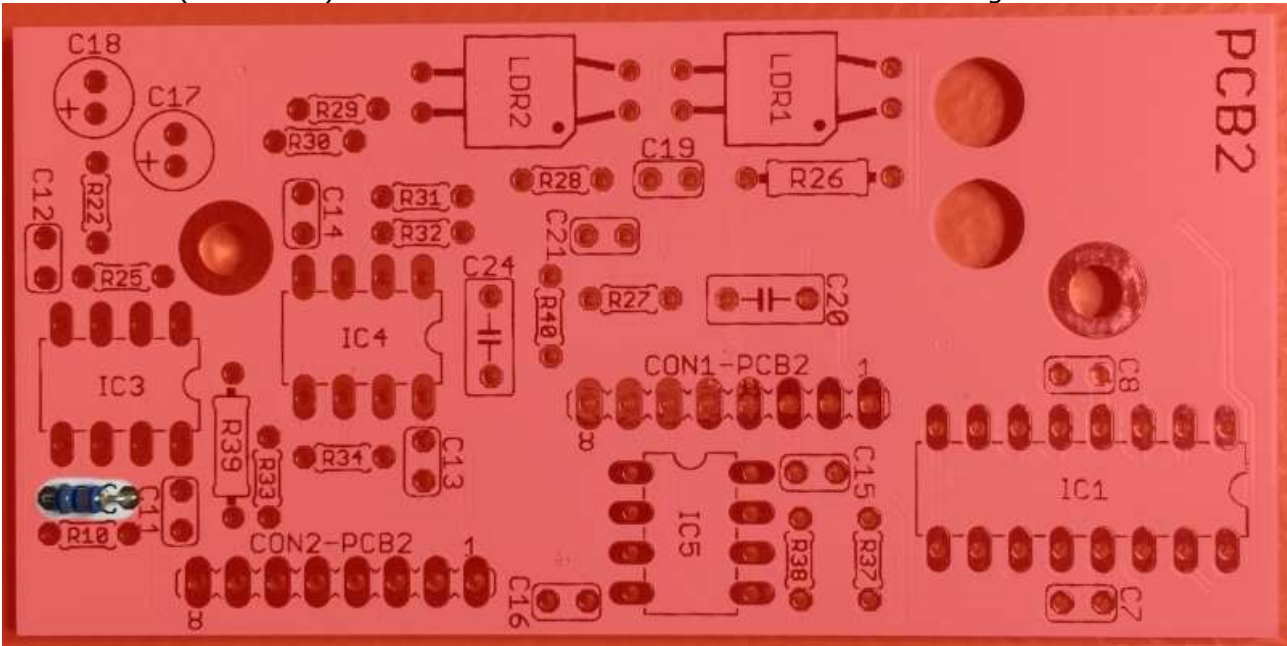

R16 680K

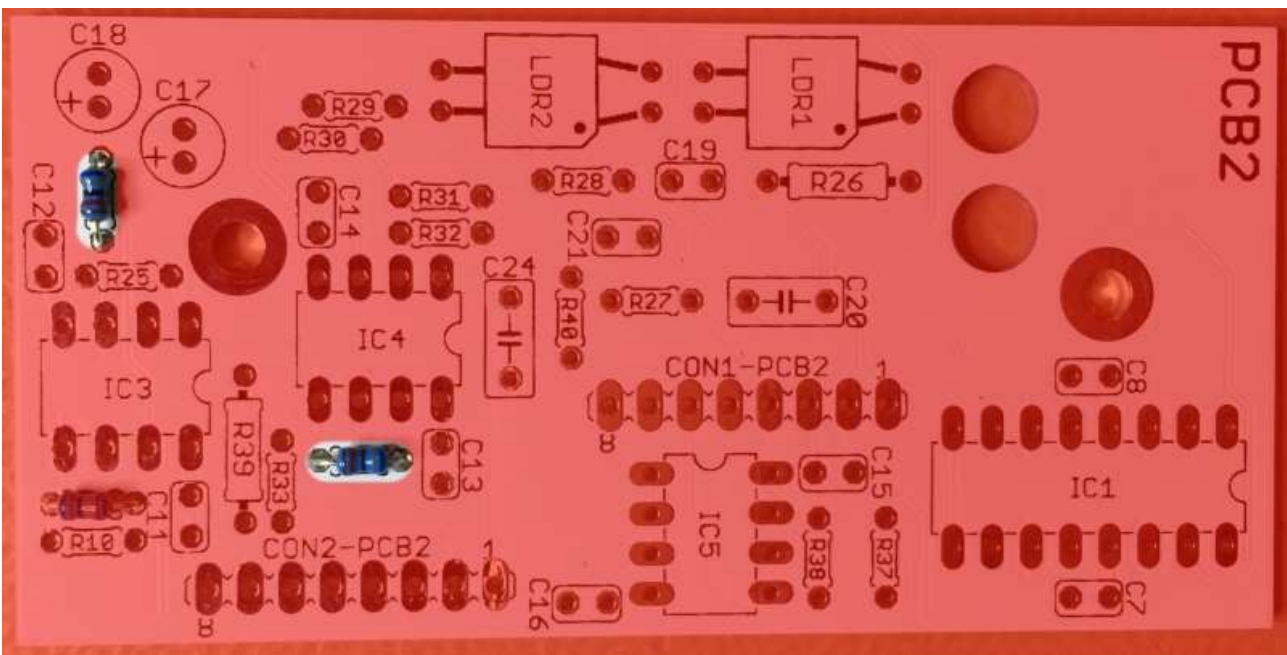

R22, R34 68K

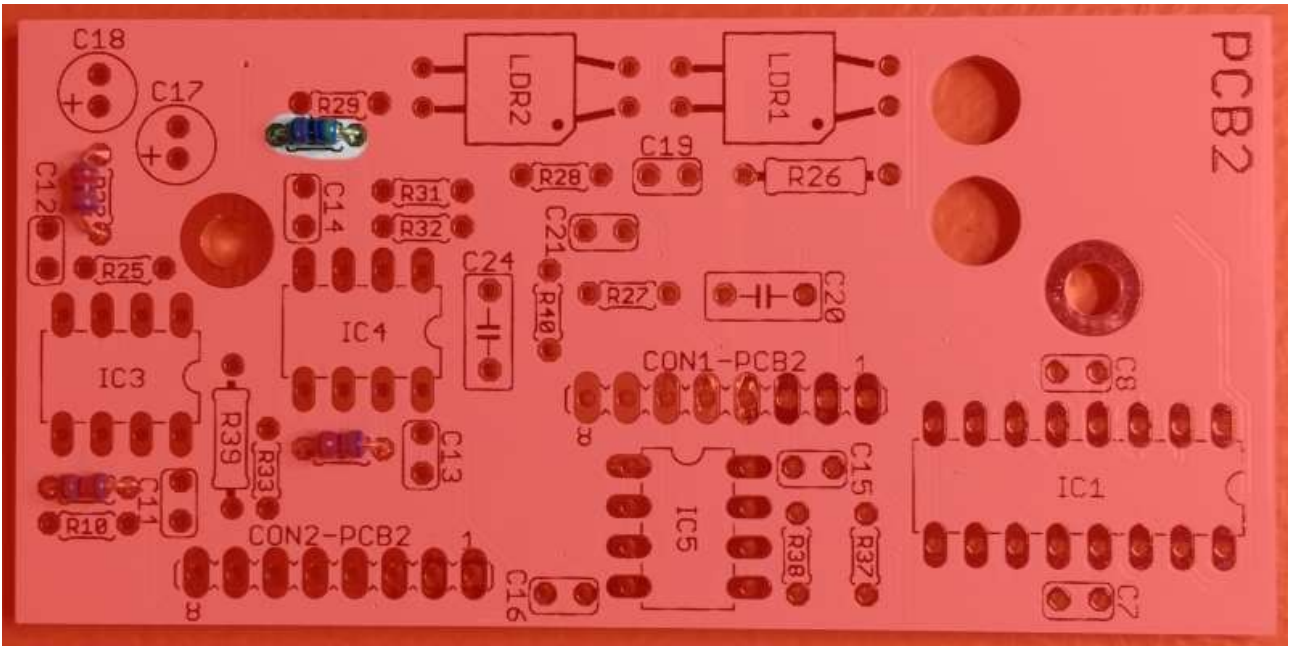

R30 47K

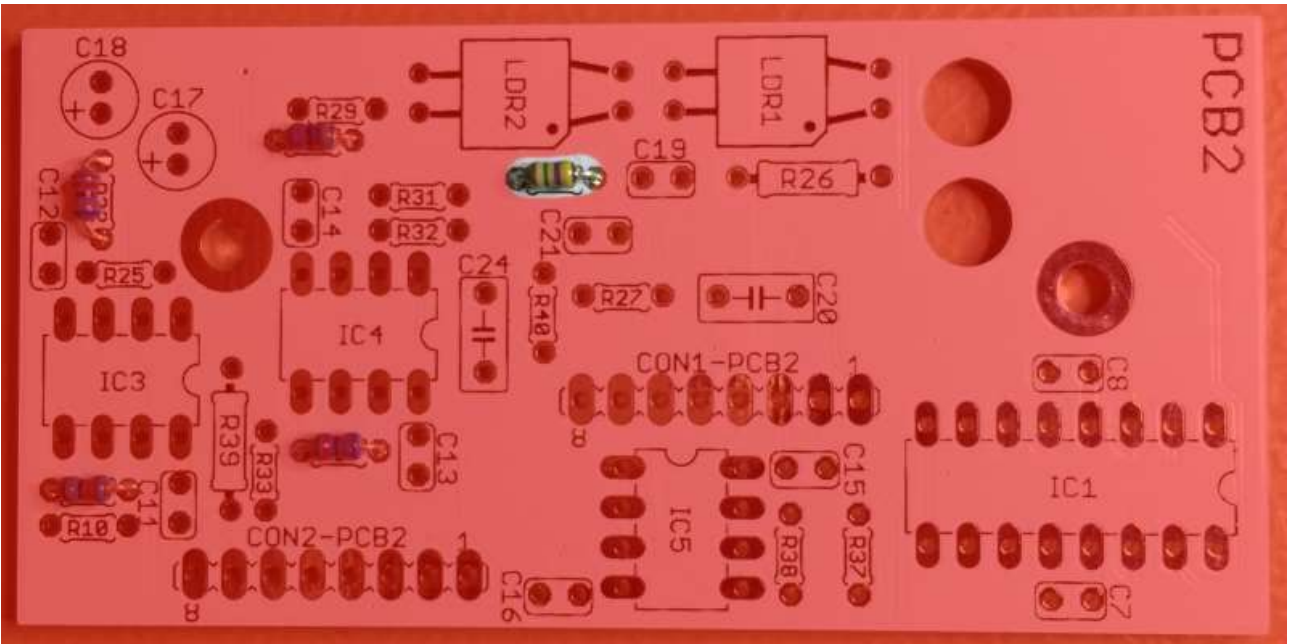

R28 4.7M

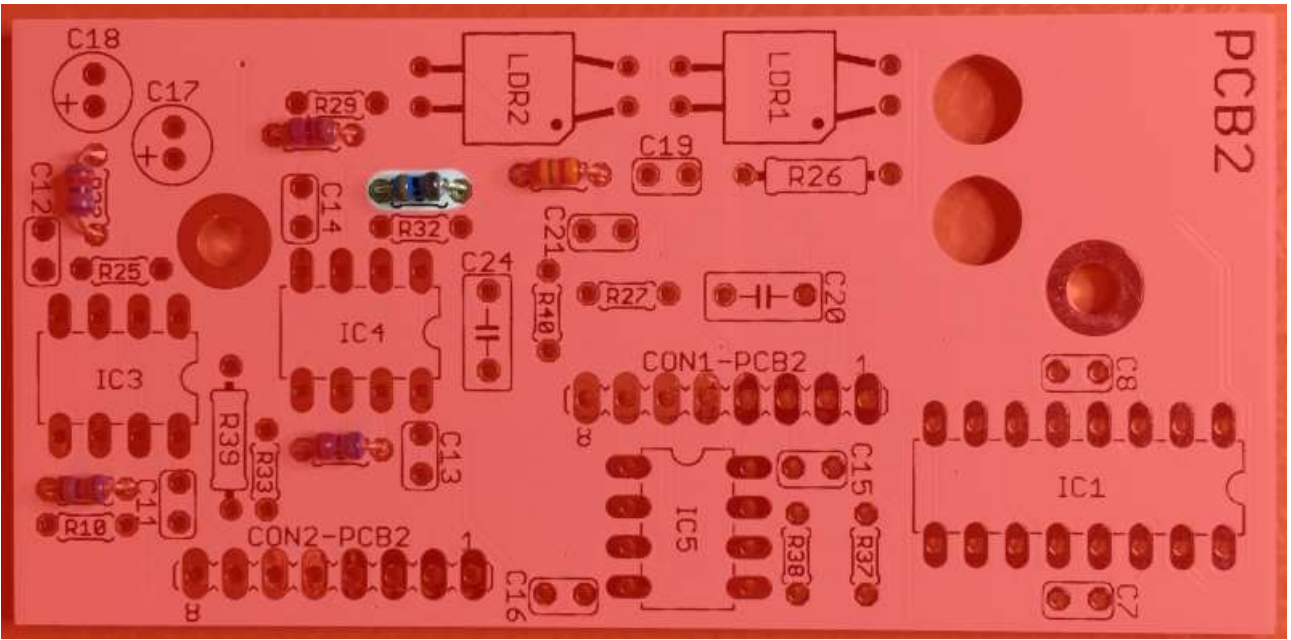

R31 330K

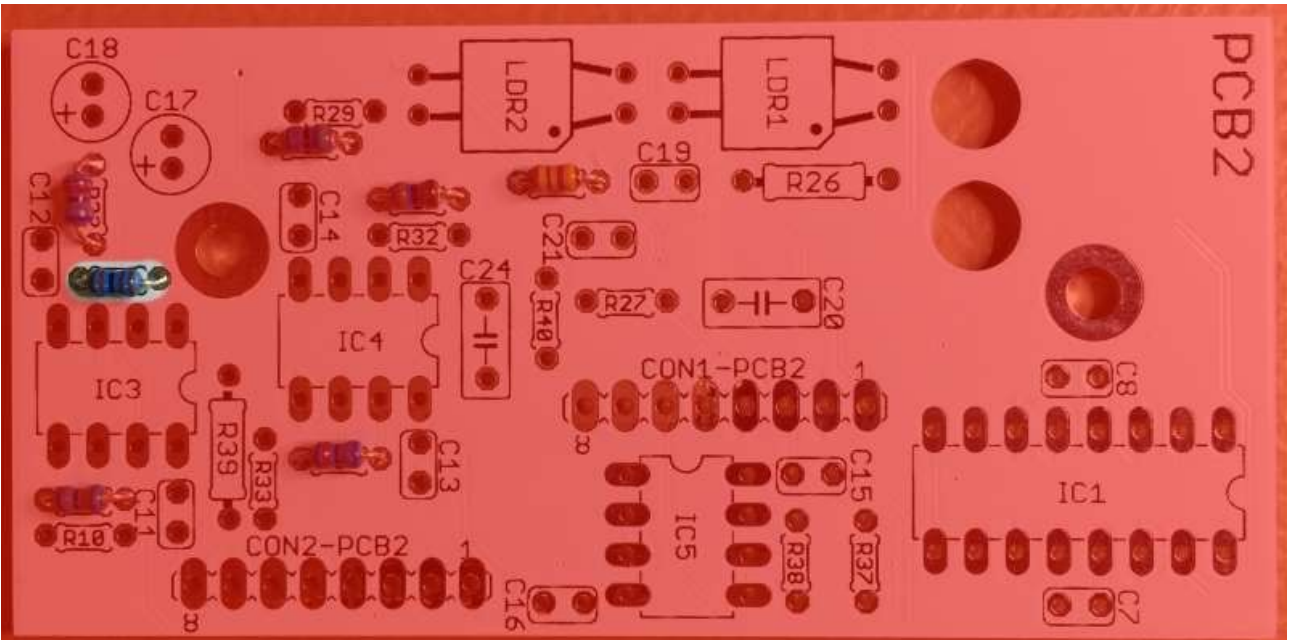

R25 12K

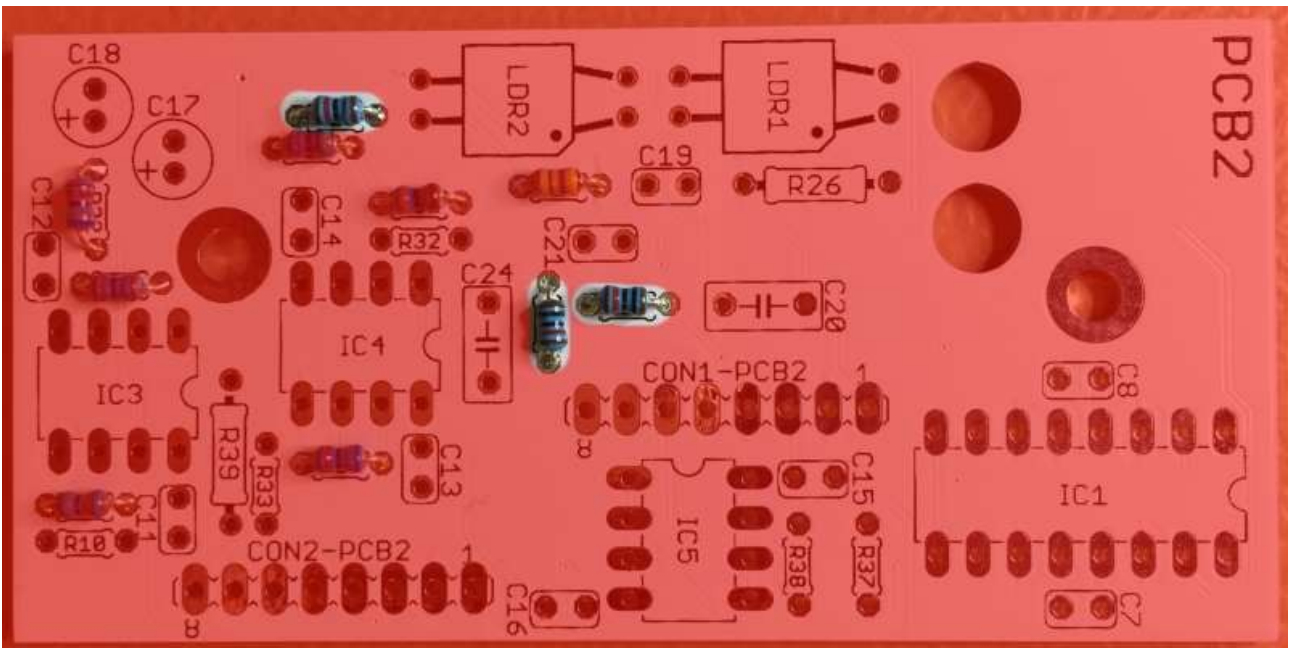

R27, R29, R40 10K

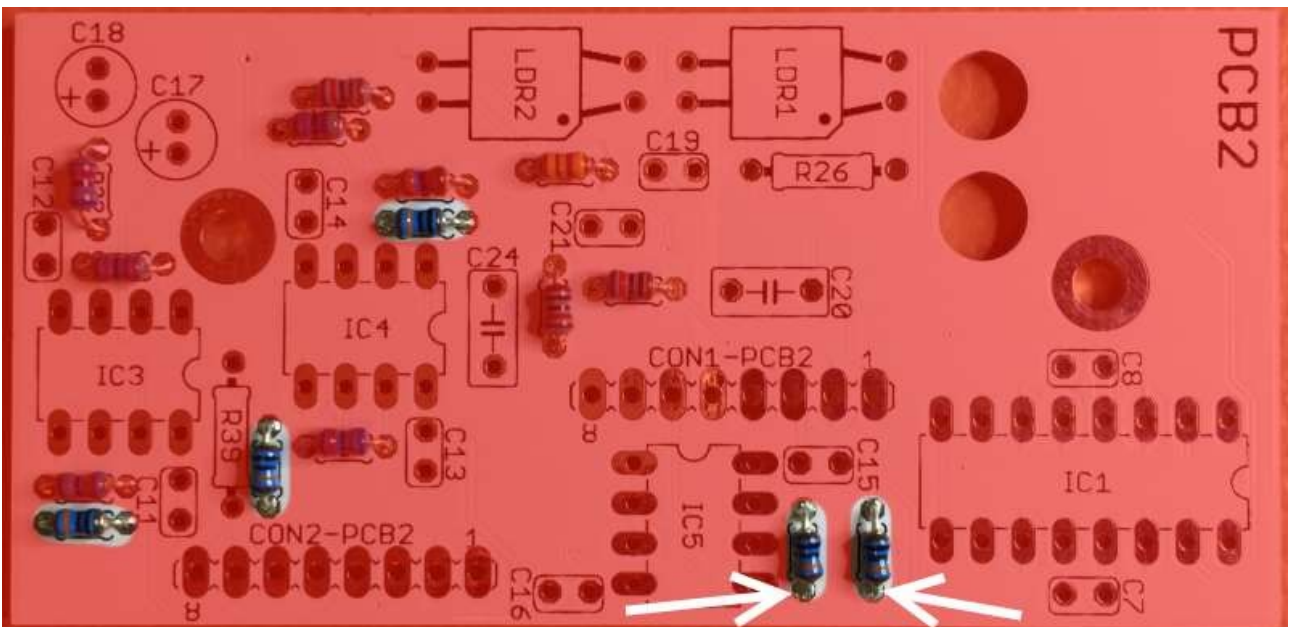

R10, R32, R33, R37, R38 100K

If you have **PCB2 version 1.0** you need to save one of the resistor pins. Use it to solder a bridge/jumper across the two pins closest to the PCB edge on **R37 and R38**. The position is marked by arrows in the pictures. If you have PCB2 version 1.1 you can skip this, it's unnecessary but won't ruin anything if you happen to do it anyway by mistake. This is the only difference between the PCB2 versions.

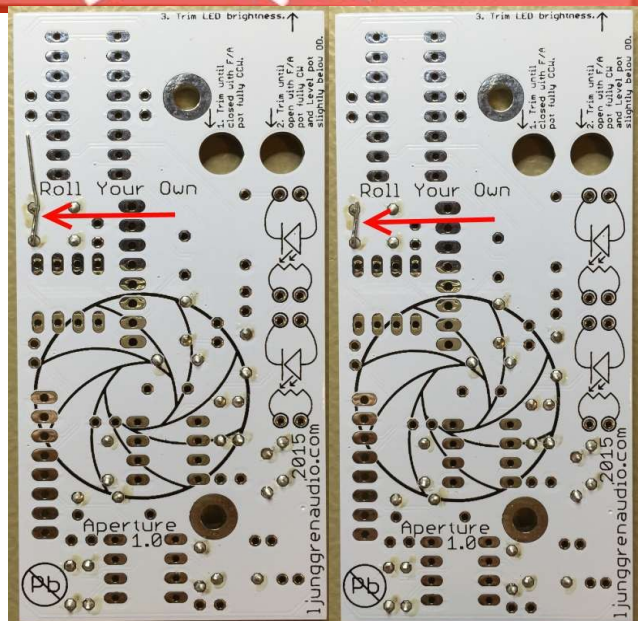

Step 2

Solder regular sized (ca 7mm) resistors. Resistors are not sensitive to mounting direction.

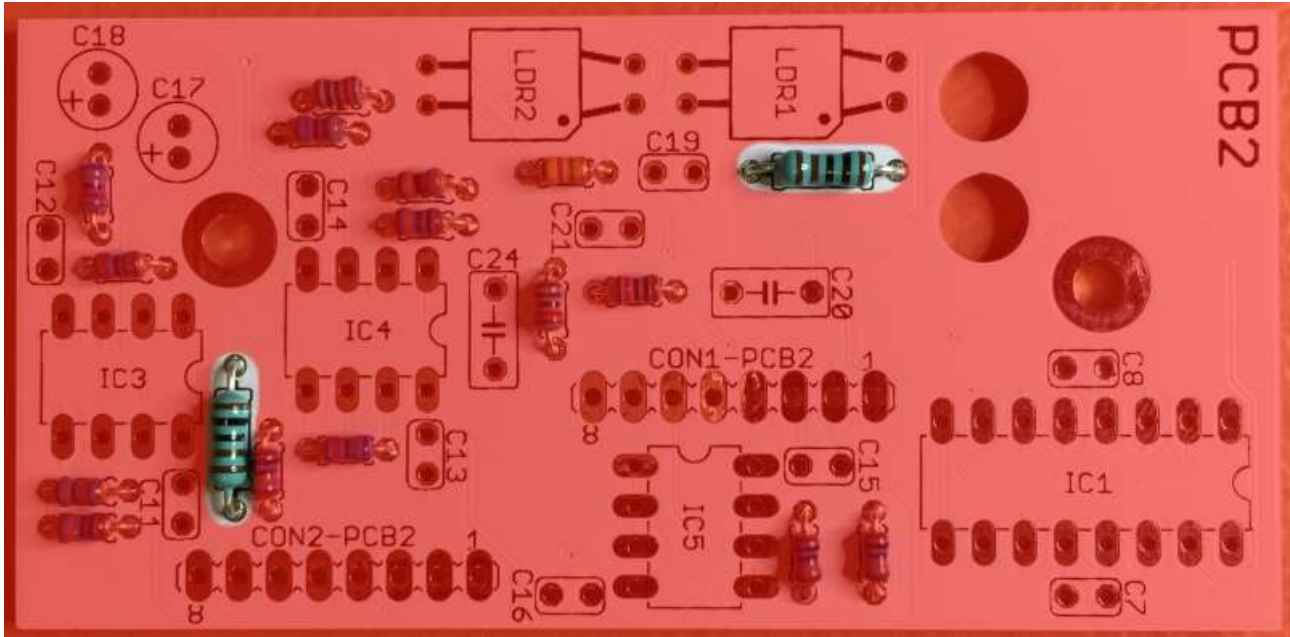

R26, R39 1K

Step 3

Solder ceramic capacitors. Ceramic capacitors are not sensitive to mounting direction.

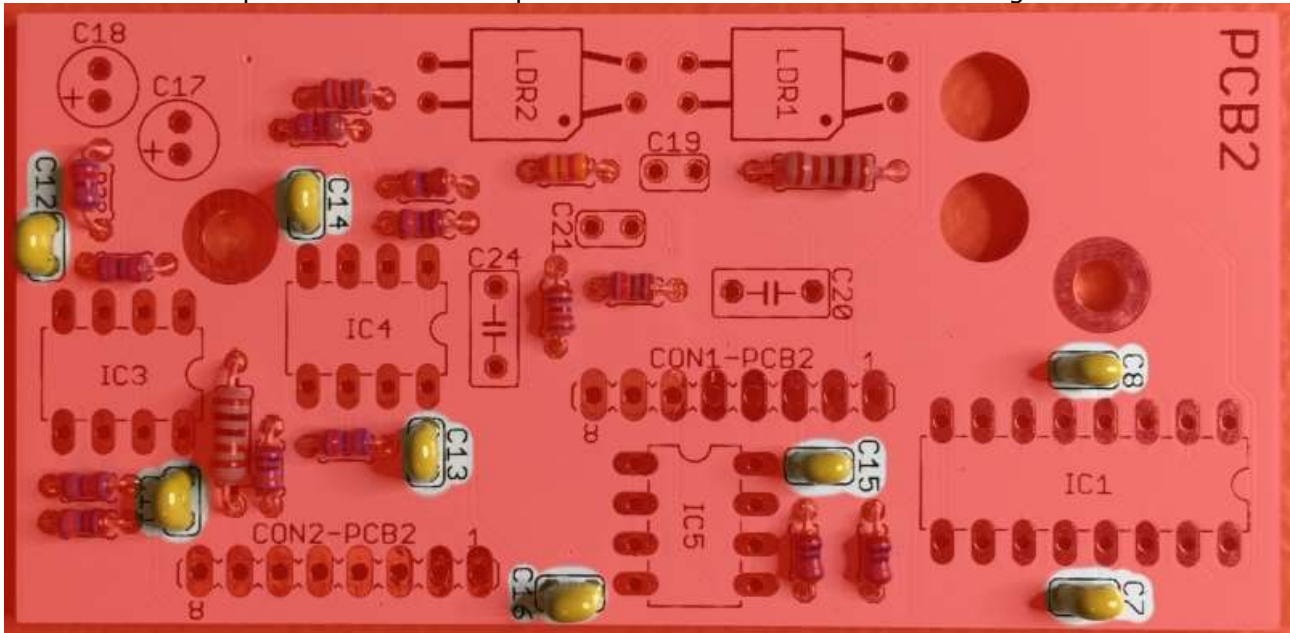

C7, C8, C11, C12, C13, C14, C15, C16 100nF

The last ceramic capacitors will follow in a later step as they are taller.

Step 4

Solder IC sockets. Match the IC sockets indent (marking pin 1 side) with the silk screens.

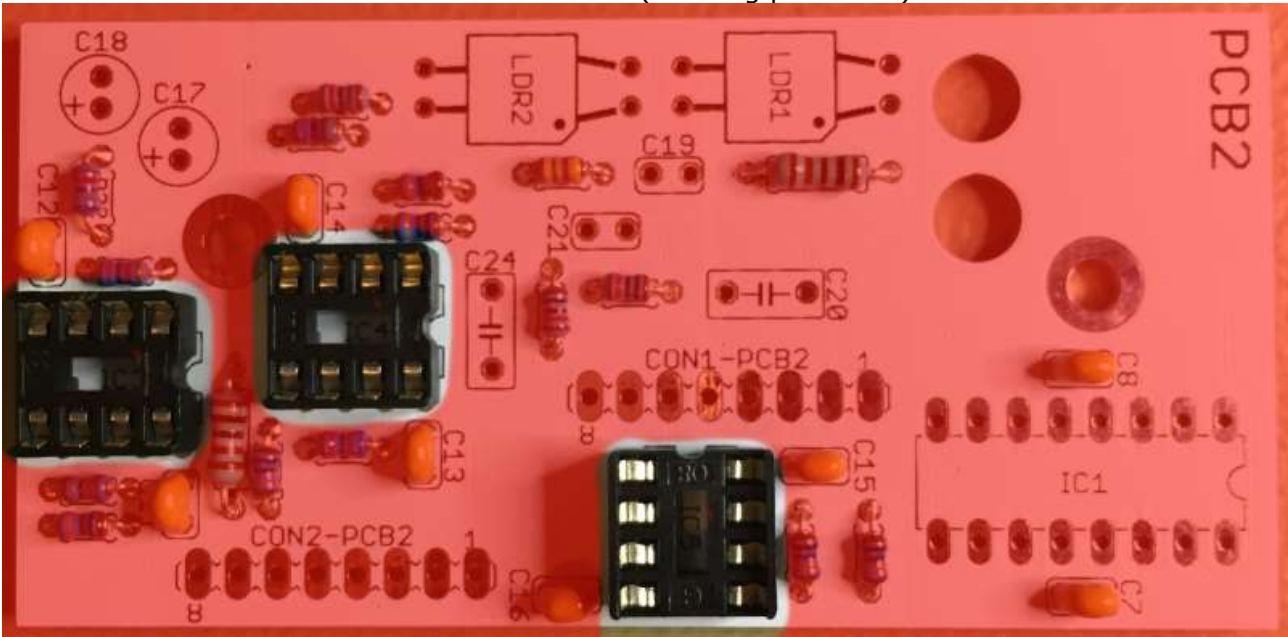

IC3, IC4, IC5 8 pin DIP sockets. IC's will be mounted later.

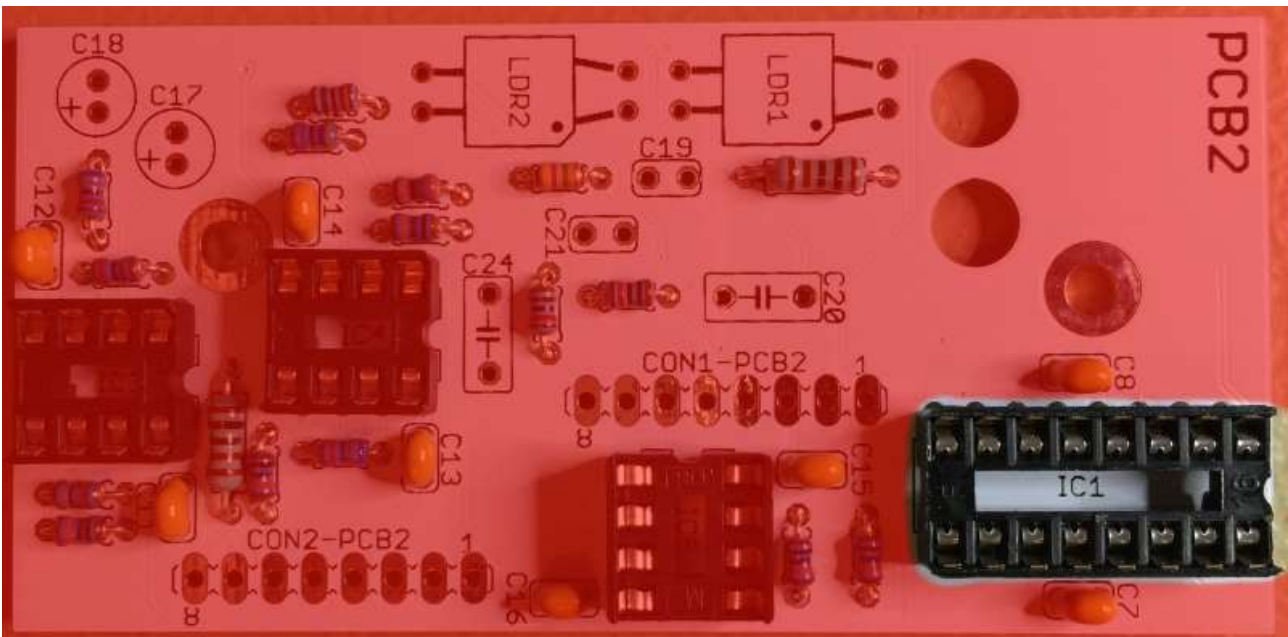

IC1 16 pin DIP socket. IC will be mounted later.

Step 4

Solder vactrol/optocoupler sockets. Not sensitive to mounting direction.

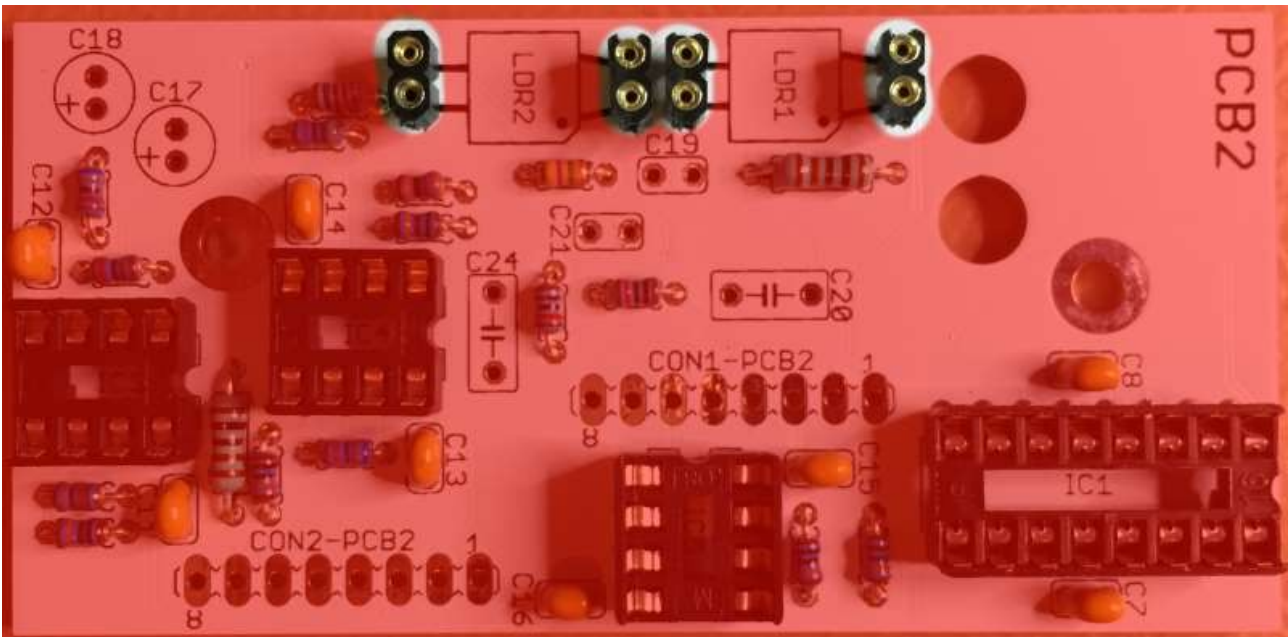

2x LDR1, 2x LDR2 2 pin SIP socket. Optocouplers will be mounted later.

Step 6

Solder ceramic capacitors. Ceramic capacitors are not sensitive to mounting direction. We use TDK brand in the kit and pre-assembled.

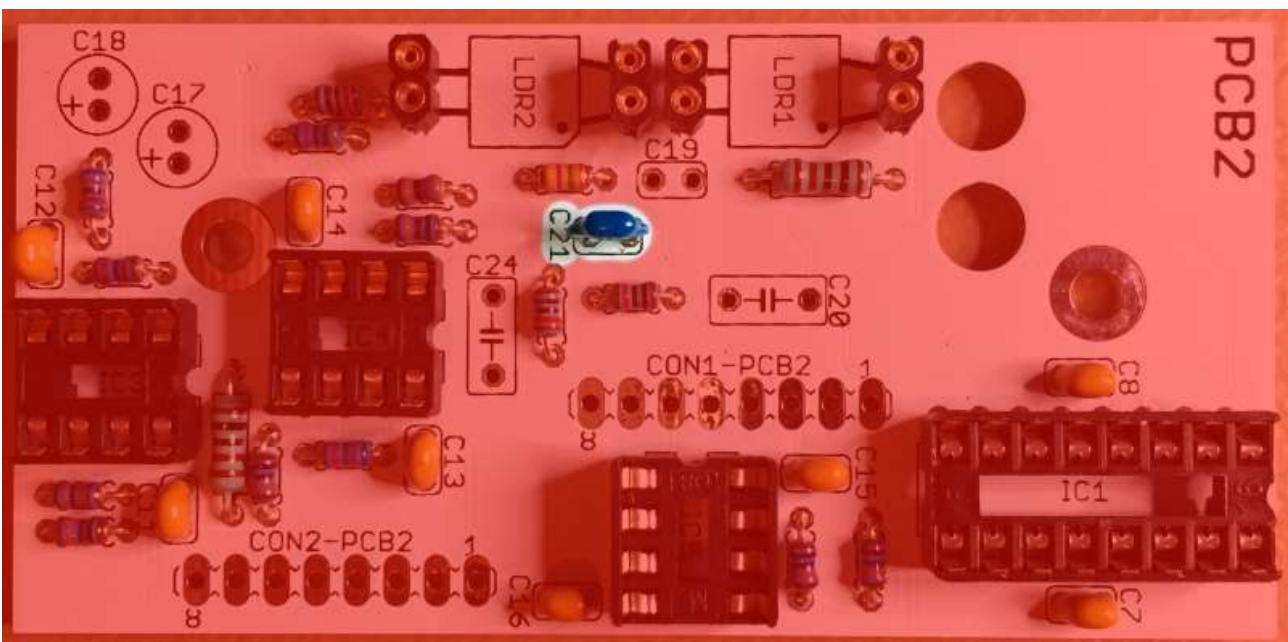

C21 33nF

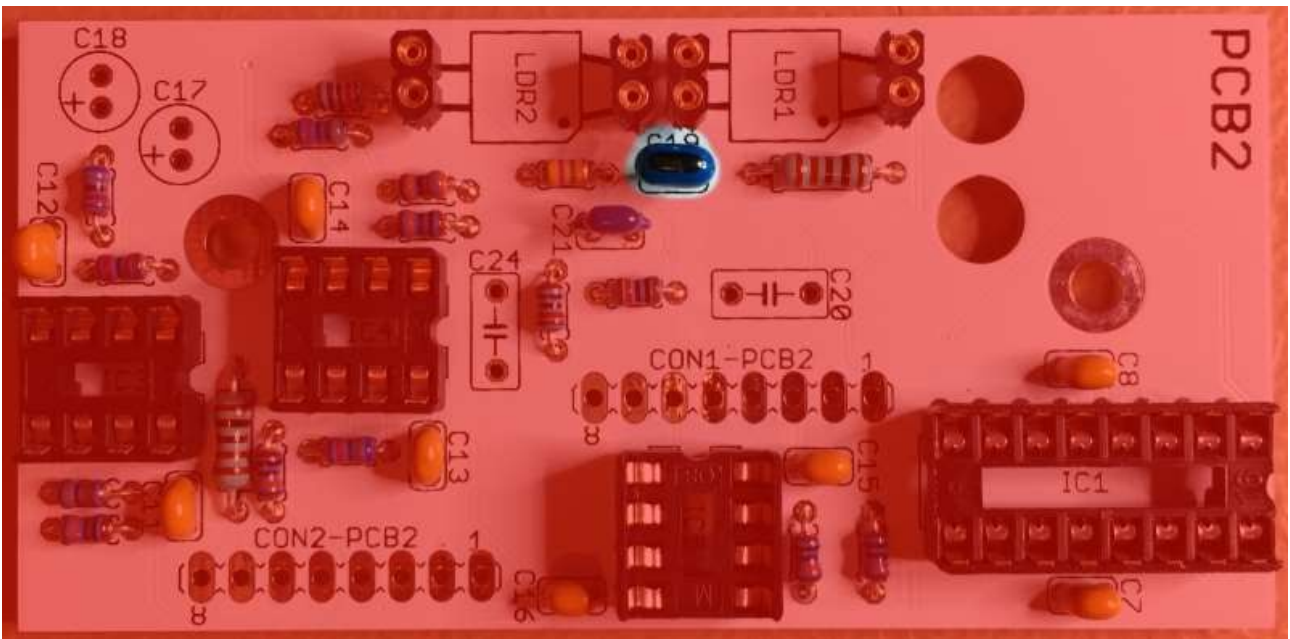

C19 68nF

Step 7

Solder electrolytic capacitors. Electrolytic capacitors are sensitive to mounting direction. Put the long pin in the hole marked with a + (anode) on the silkscreen. The opposite side is marked with - (cathode) on the electrolytic capacitor. We use Panasonic brand in the kits and pre-assembled.

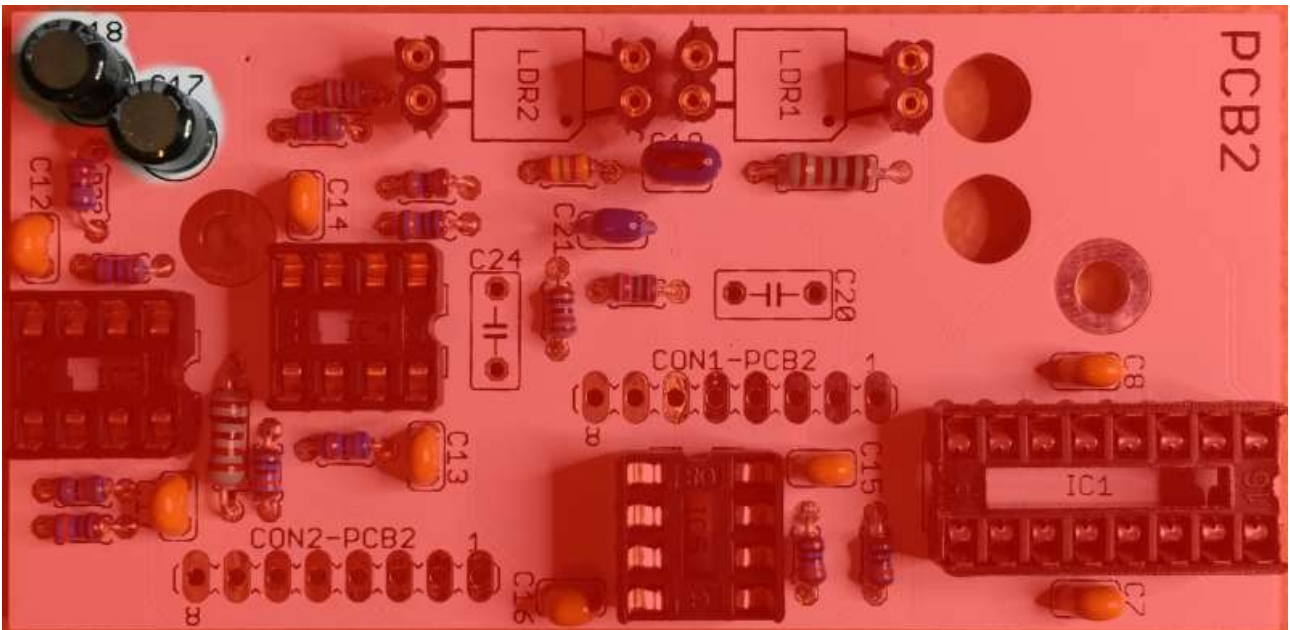

C17, C18 10 μ F AC coupling

Step 8

Solder polybox capacitors. Polybox capacitors are not sensitive to mounting direction. We use WIMA brand MKS2 model in the kit and pre-assembled.

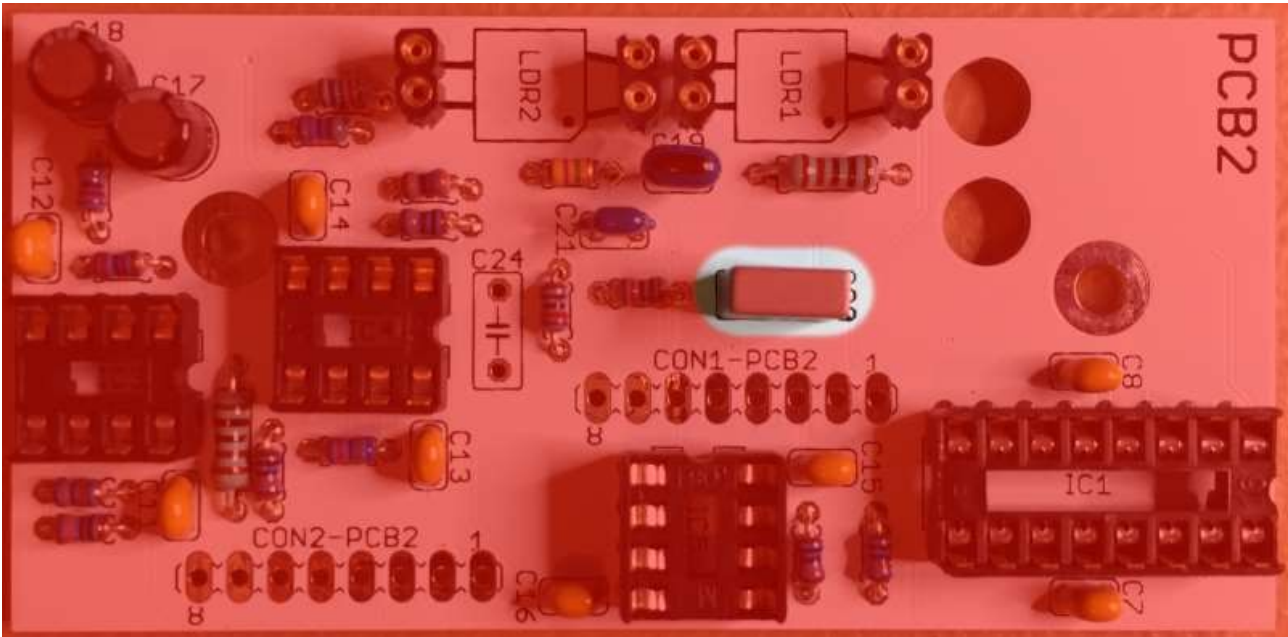

C20 220nF

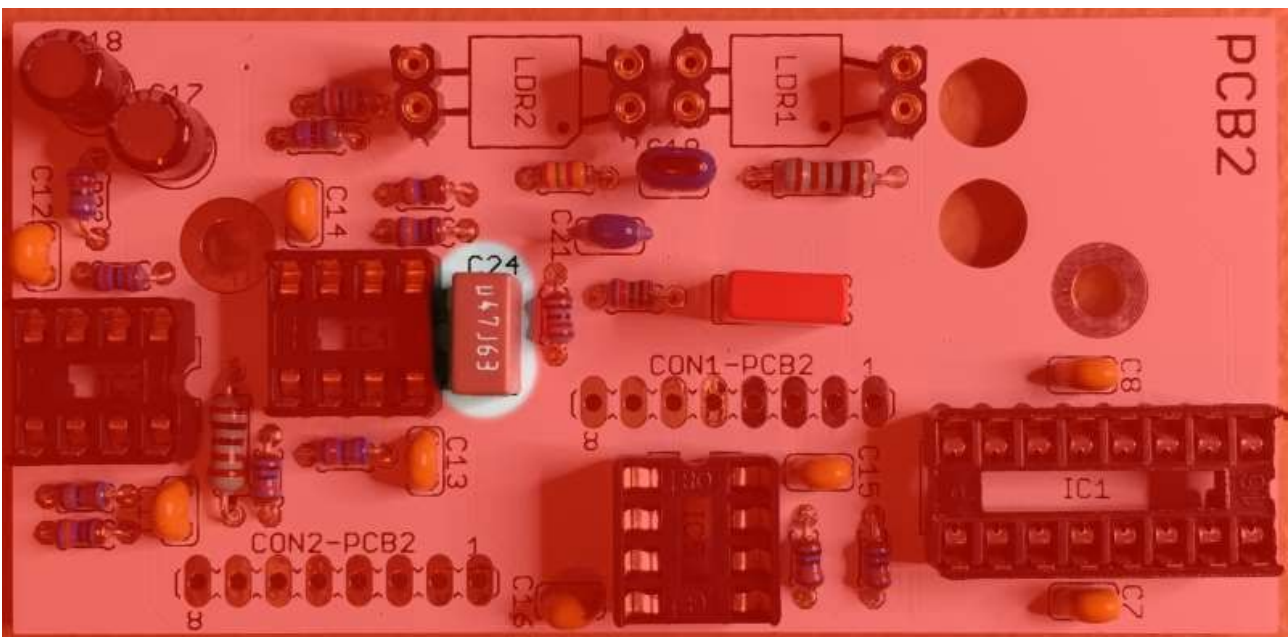

C24 470nF

Step 9

Insert the ICs in the sockets.

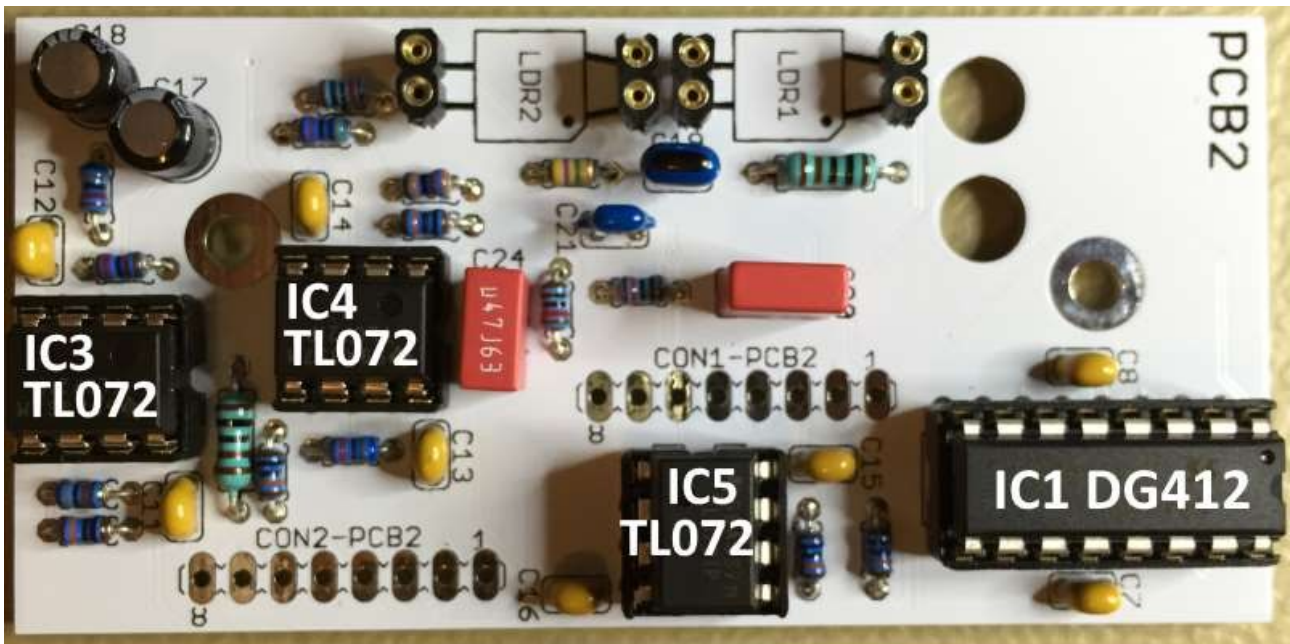

IC1 DG412

IC3, IC4, IC5 TL072

Step 10

Insert the vactrols/optocouplers in the sockets. This is a fiddly step, be careful not to cut the pins too short, it's easier to cut them a little more if needed than to realise they are too short. Make sure the optocouplers dot match the dot/bevel marking in the silk screen. **Be careful to bend them in the correct angle in relation to the dot on the side.** If you need to re-bend them in the opposite direction there is a little risk of the pins to break. It's easiest to bend the pins with some pliers.

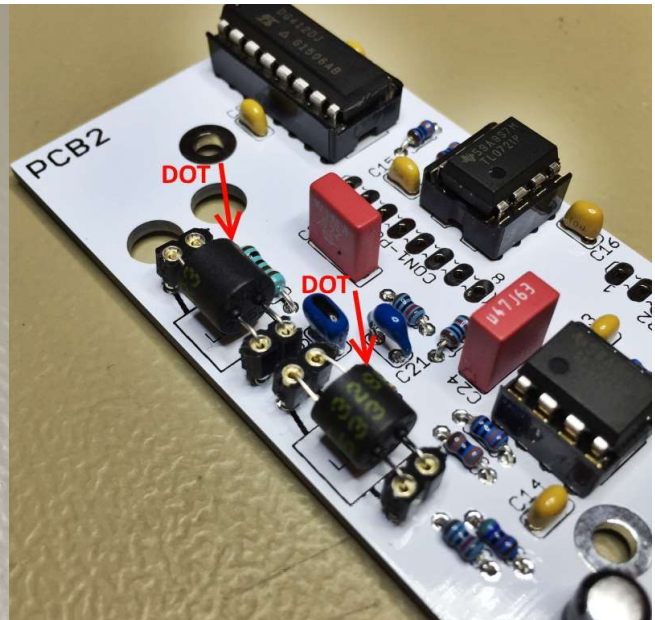
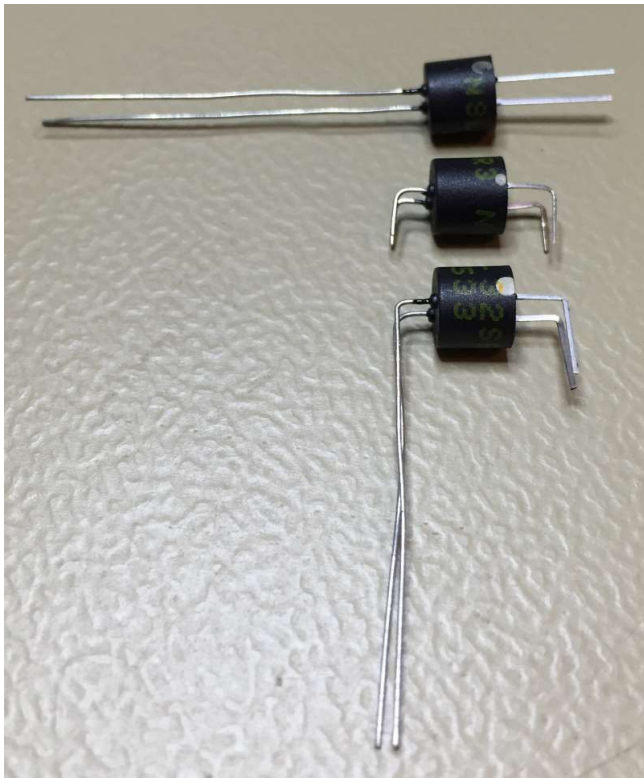

Step 11

Leave PCB2 on the side with CON1-PCB2 and CON2-PCB2 not soldered.
Now it's time for PCB1.

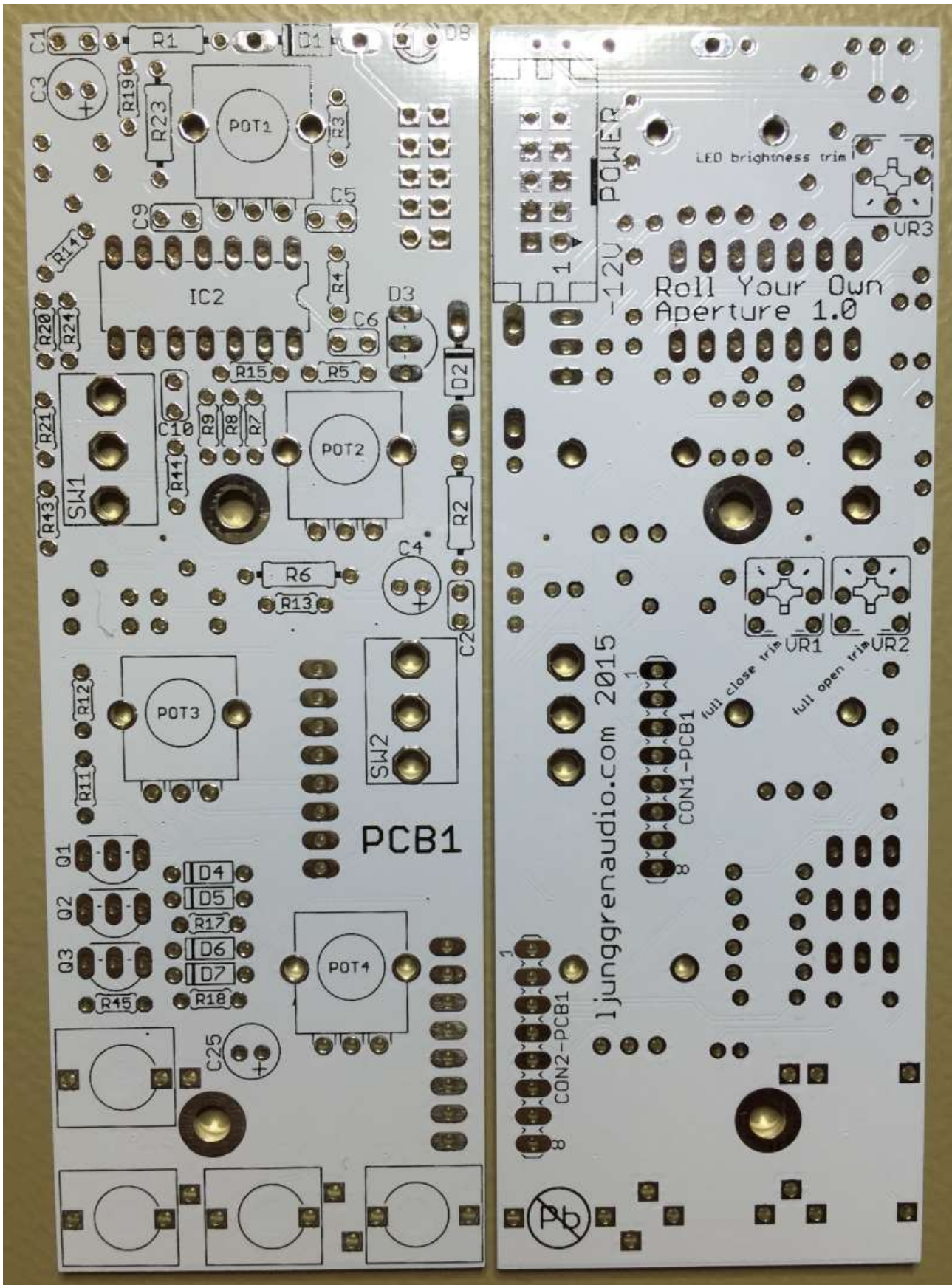

Empty PCB1 top & bottom.

Step 12

Solder small signal diodes. Diodes are sensitive to mounting direction, make sure the stripe on the diode match the stripe on the silkscreen.

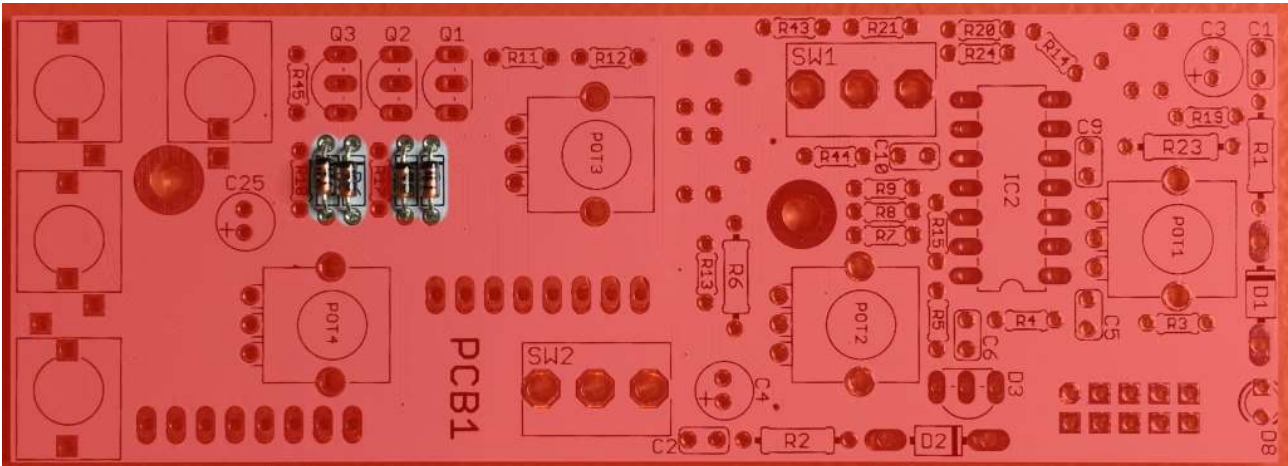

D4, D5, D6, D7 1N4148

Step 13

Solder small (ca 3.5mm) resistors. Resistors are not sensitive to mounting direction.

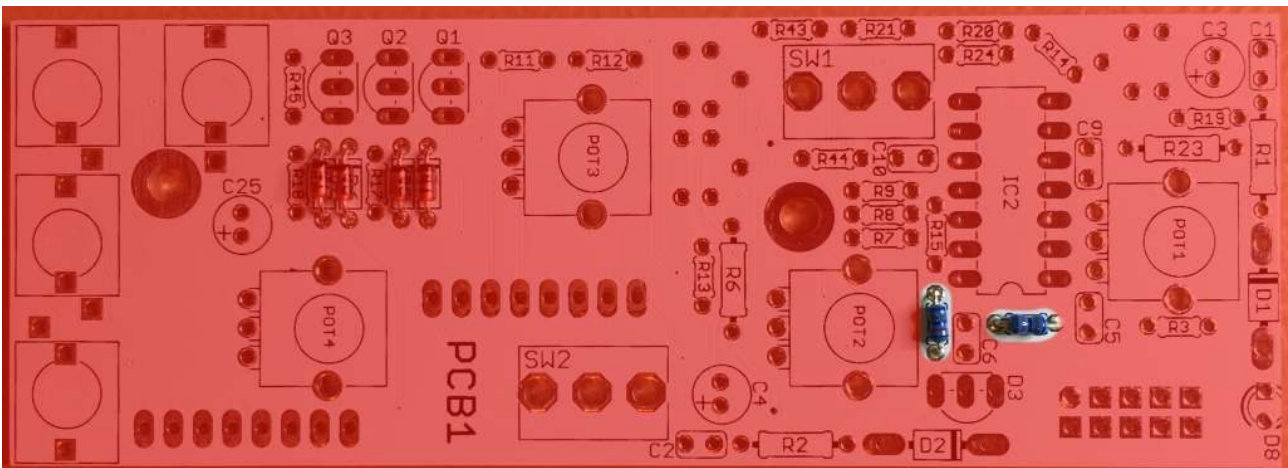

R4, R5 68K

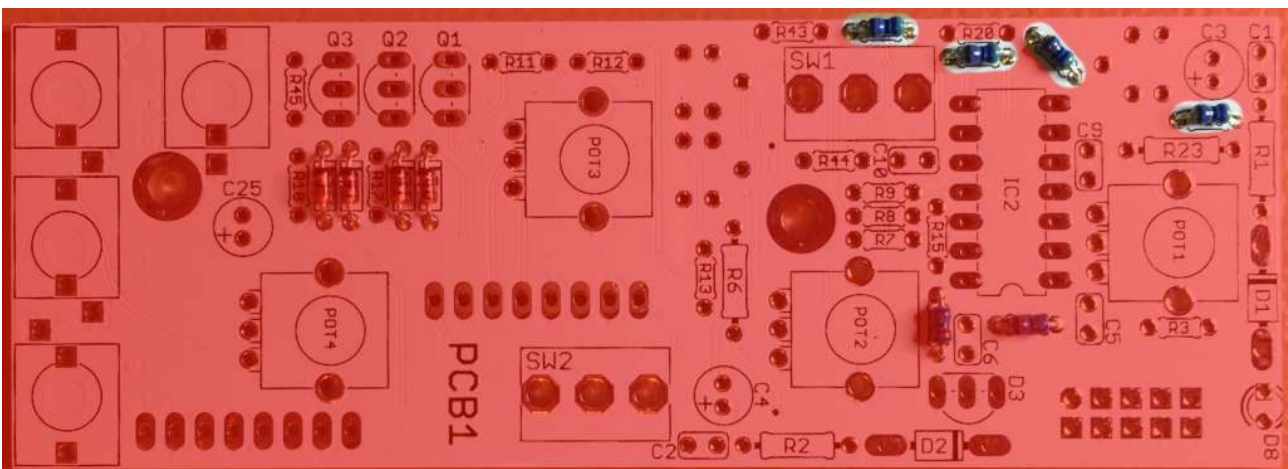

R14, R19, R21, R24 47K

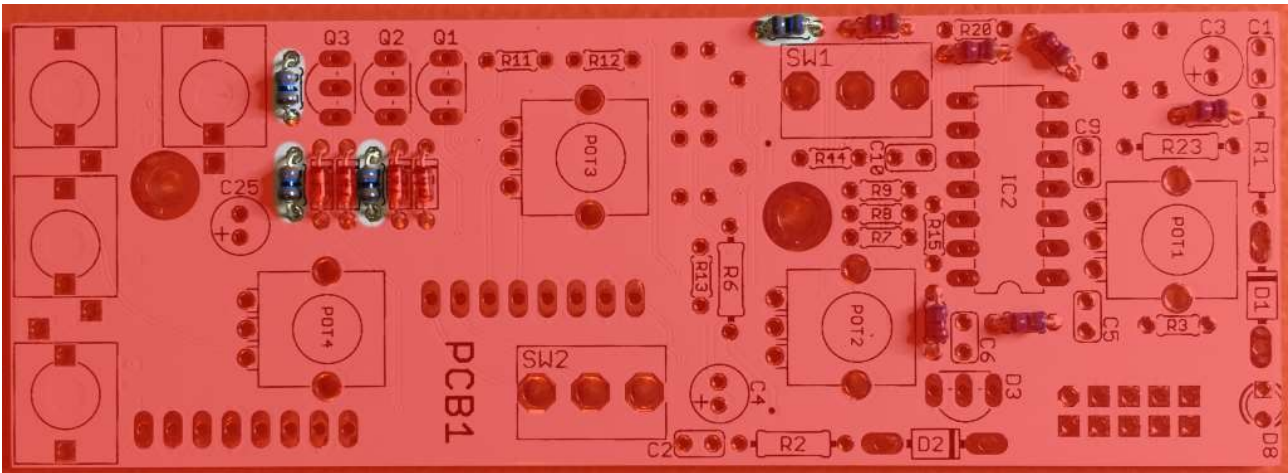

R17, R18, R43, R45 330K

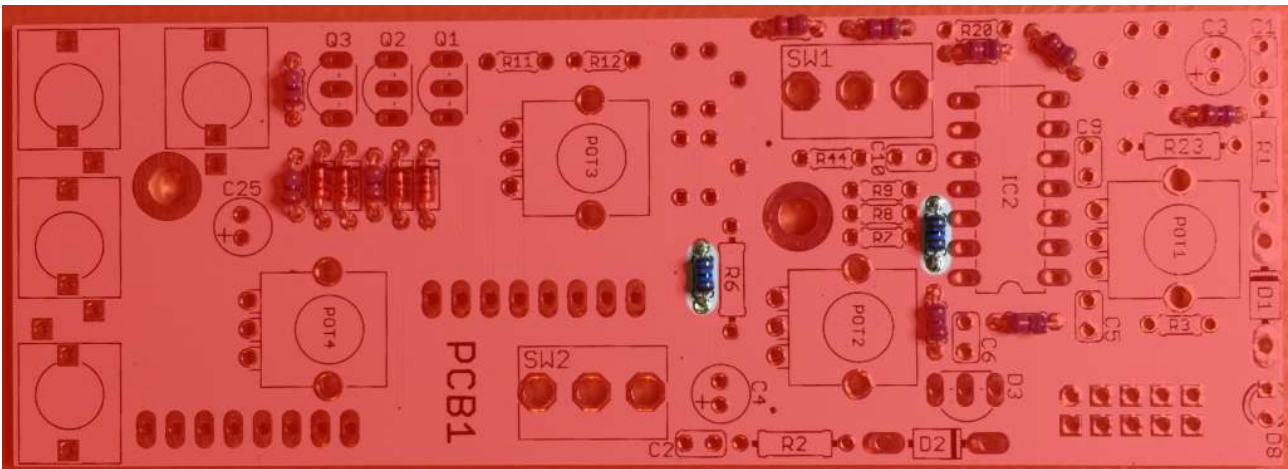

R13, R15 12K

The next resistor is **zero ohm**. Use a **cut off pin** from another component to form a jumper and it will do the exact same job as a zero ohm resistor.

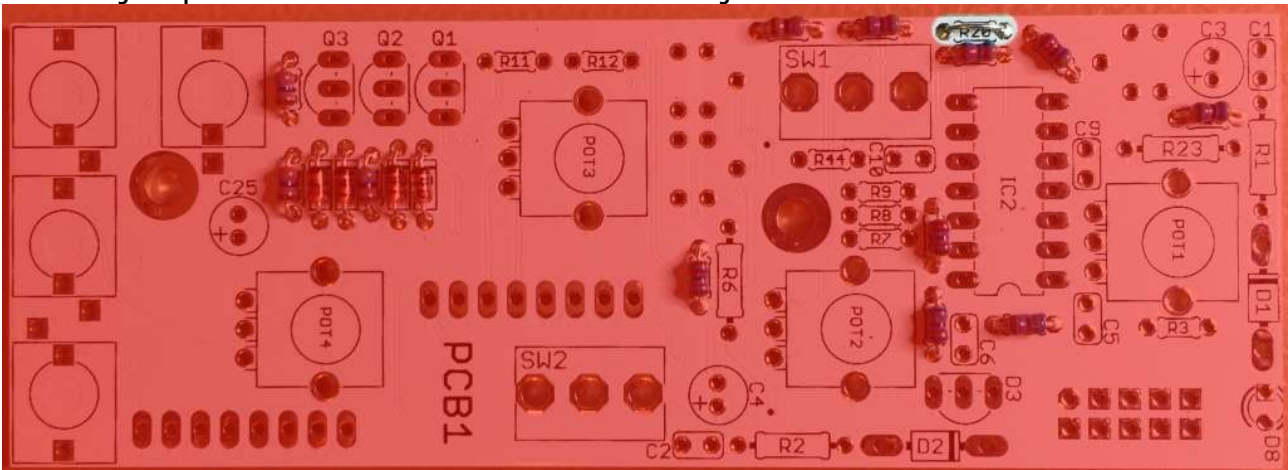

R20 zero ohm

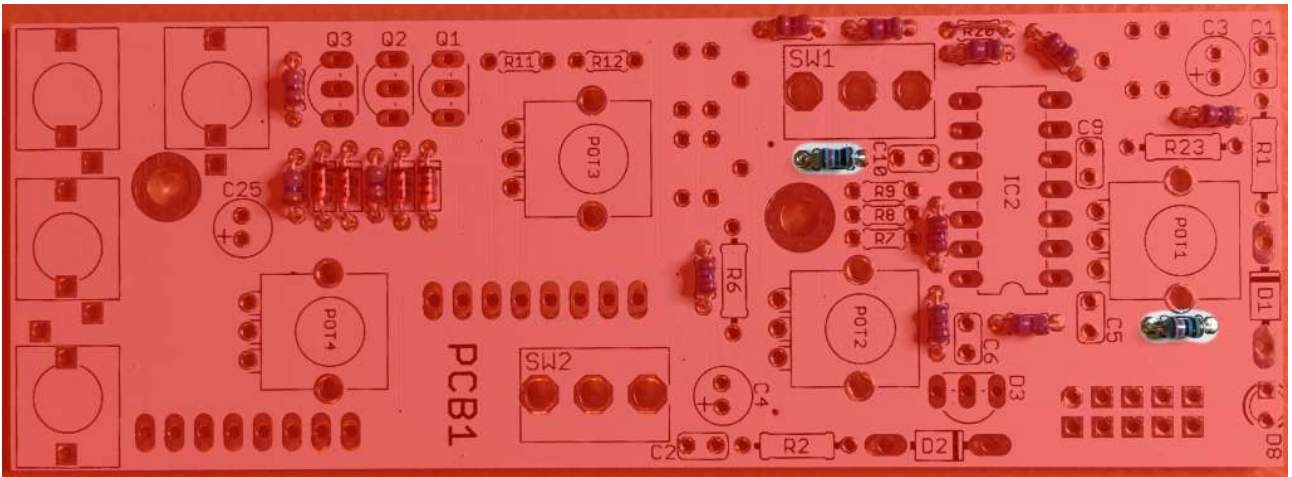

R3, R44 10K

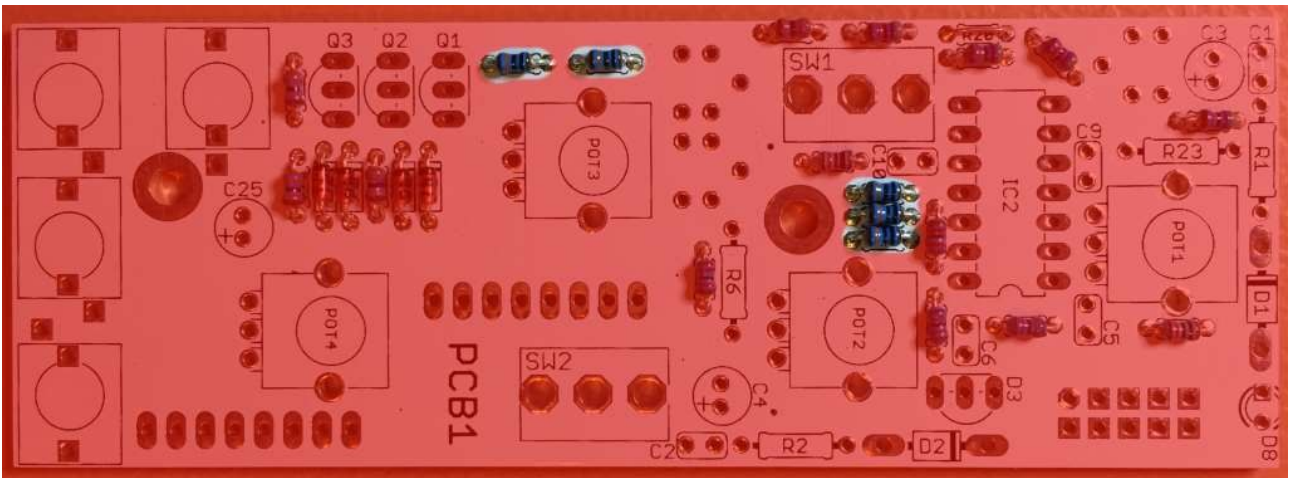

R7, R8, R9, R11, R12 100K

Step 14

Solder regular sized (ca 7mm) resistors. Resistors are not sensitive to mounting direction.

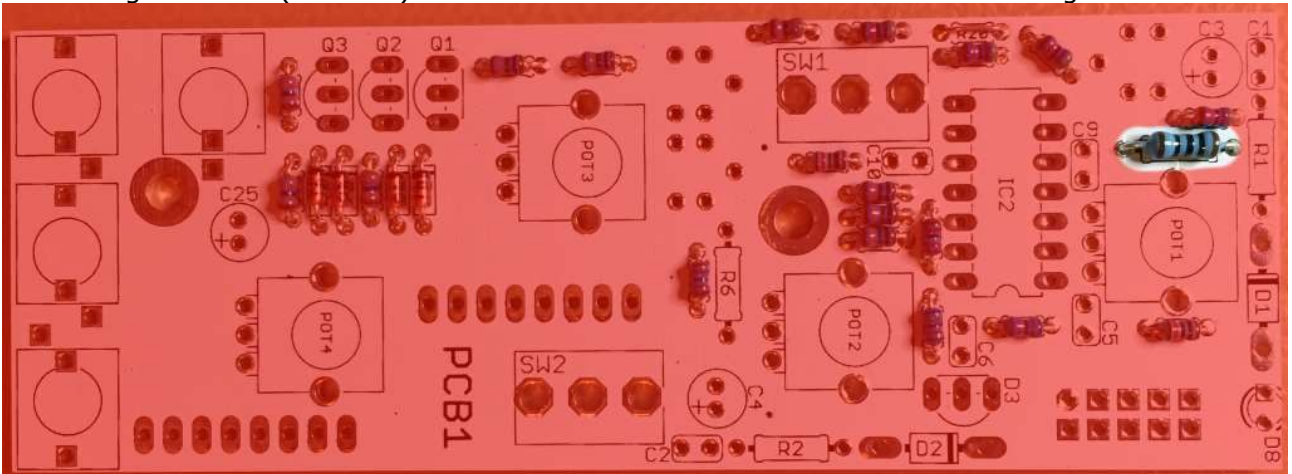

R23 100R

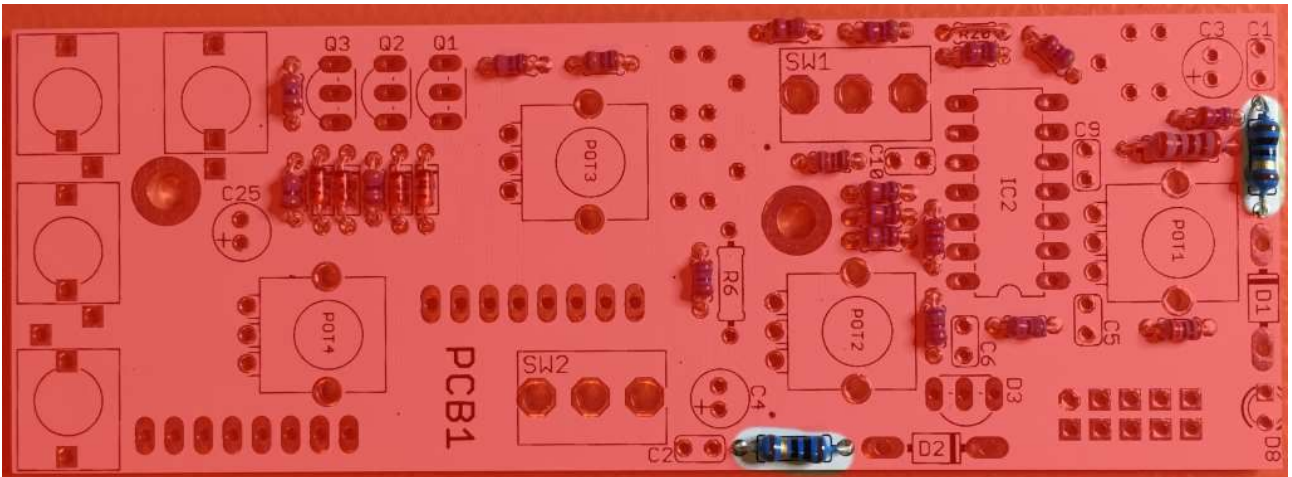

R1, R2 10R

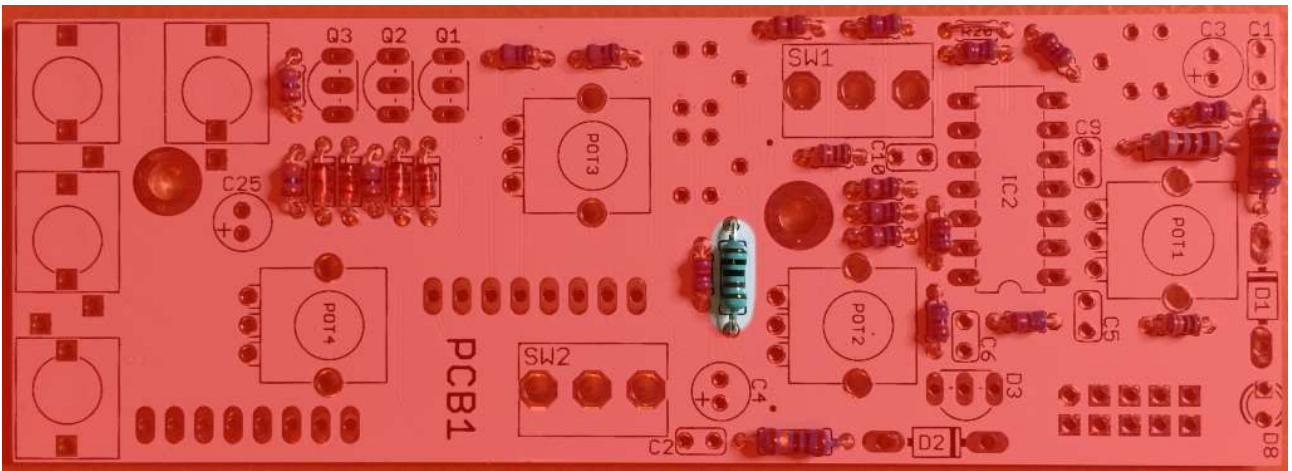

R6 1K

Step 15

Solder power polarity protection diodes. Diodes are sensitive to mounting direction, make sure the stripe on the diode match the stripe on the silkscreen.

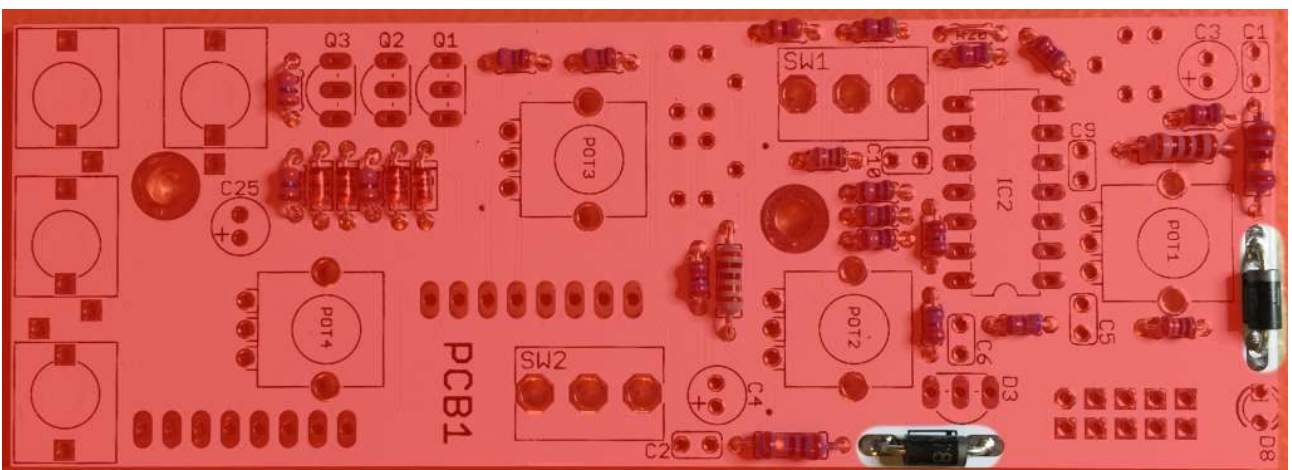

D1, D2 1N5818

Step 16

Solder ceramic capacitors. Ceramic capacitors are not sensitive to mounting direction.

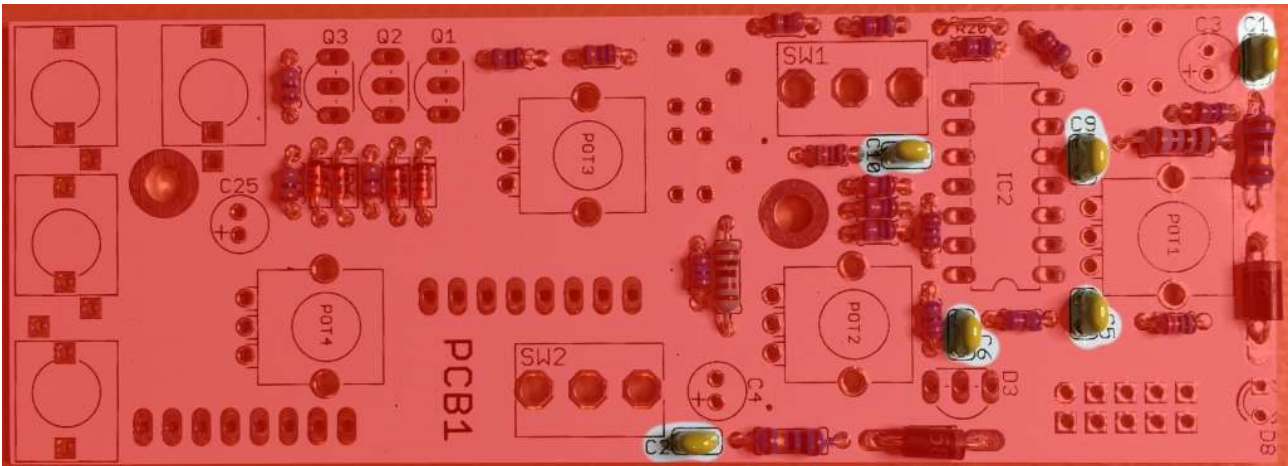

C1, C2, C5, C6, C9, C10 100nF

Step 17

Solder IC sockets. Match the IC sockets indent (marking pin 1 side) with the silk screens.

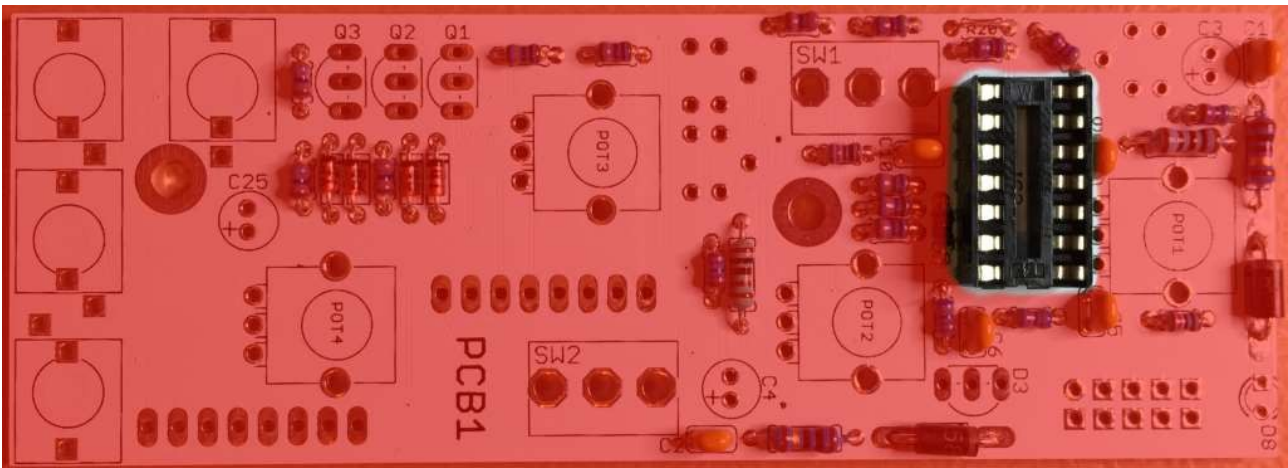

IC2 14 pin DIP socket. IC will be mounted later.

Step 18

Solder electrolytic capacitors. Electrolytic capacitors are sensitive to mounting direction. Put the long pin in the hole marked with a + (anode) on the silkscreen. The opposite side is marked with - (cathode) on the electrolytic capacitor.

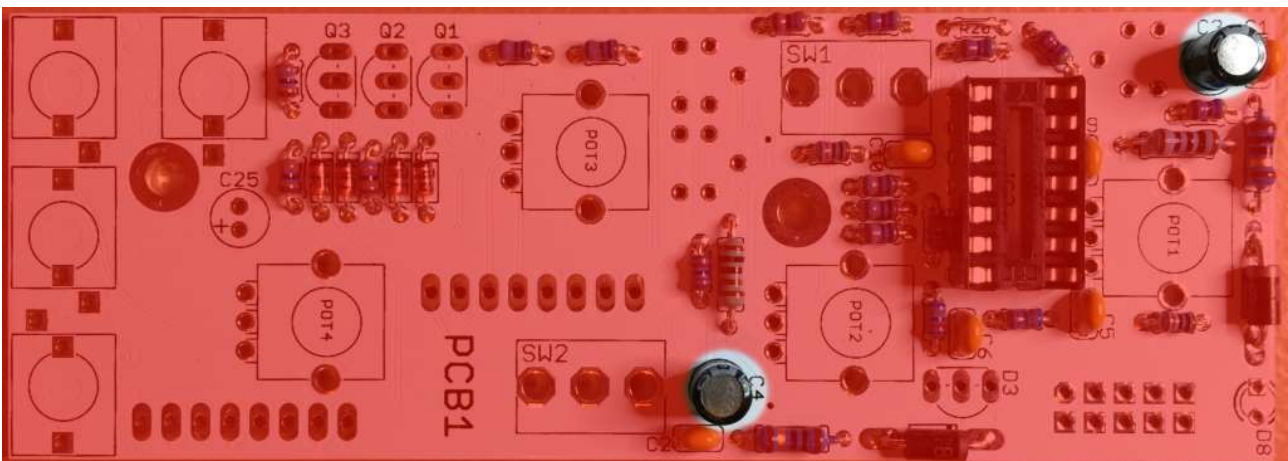

C3, C4 10 μ F

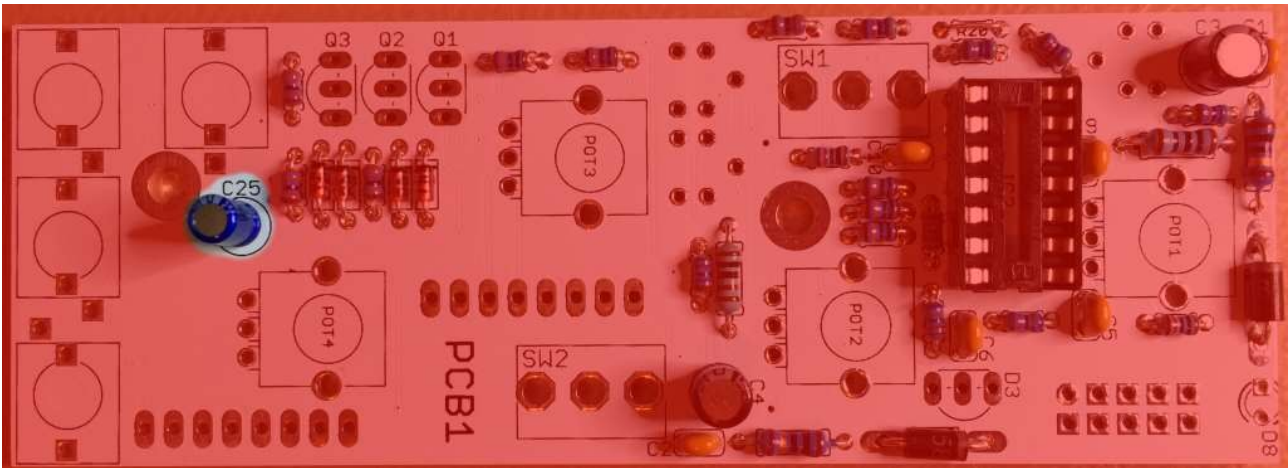

C25 2.2 μ F Klang decay capacitor, increase to make a longer klang tail and vice versa.

Step 19

Solder voltage reference diode. It looks like a transistor. Match the curved side with the silk screens.

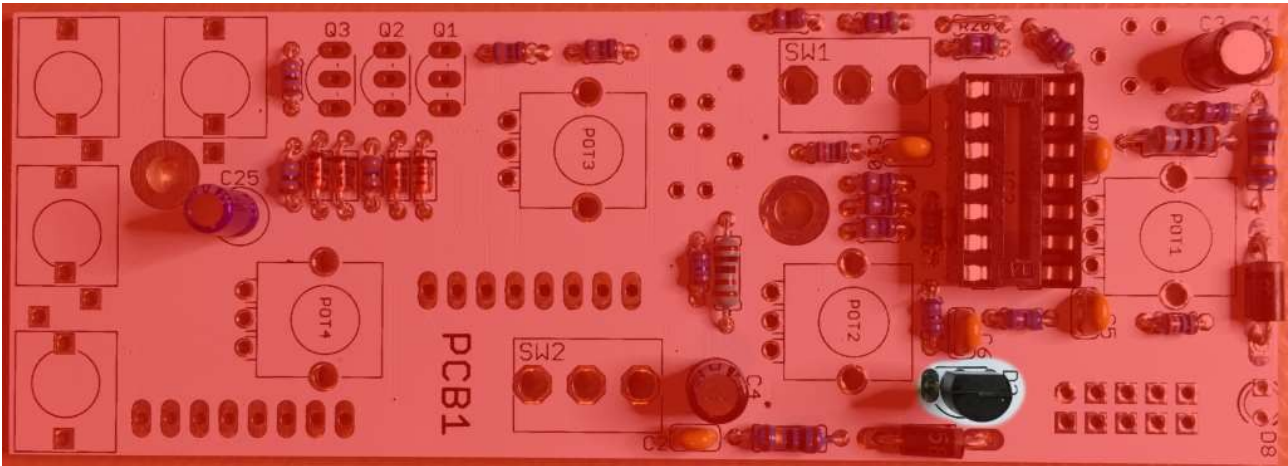

D3 LM4040 5V

Step 20

Solder transistors. Match the curved side with the silk screens.

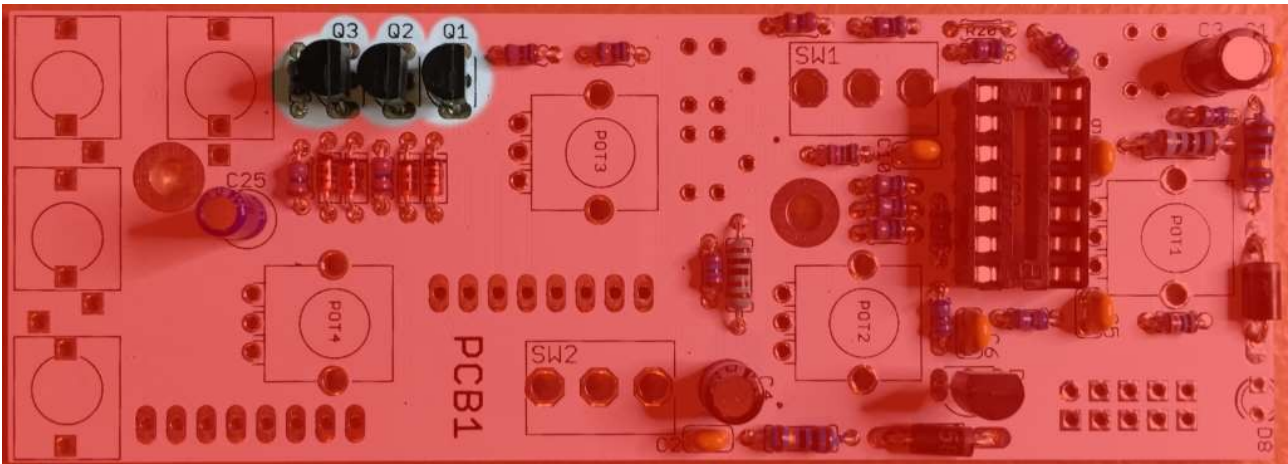

Q1, Q2, Q3 BC547

Step 21

Turn PCB1 over and solder trimmers. Only 3 of the 5 holes are used for each trimmer, the extra 2 holes are for fitting trimmers with different appearance. Use low profile trimmers like 3362P to not bump into the vactrols when the boards are sandwiched.

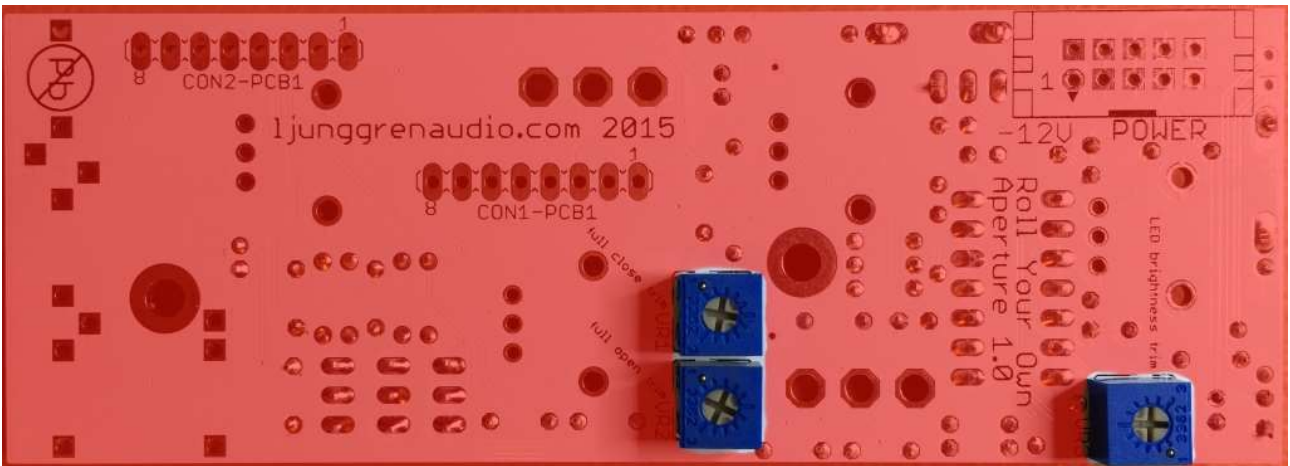

VR1, VR2, VR3 50K

Step 22

Solder the power header. Make sure the key opening is oriented in the same way as in the picture below. It's easier to avoid bent pins if you attach the power cable in the header while you are soldering.



POWER 2x5pin

Step 23

Mount the spacers with the nuts on PCB1.

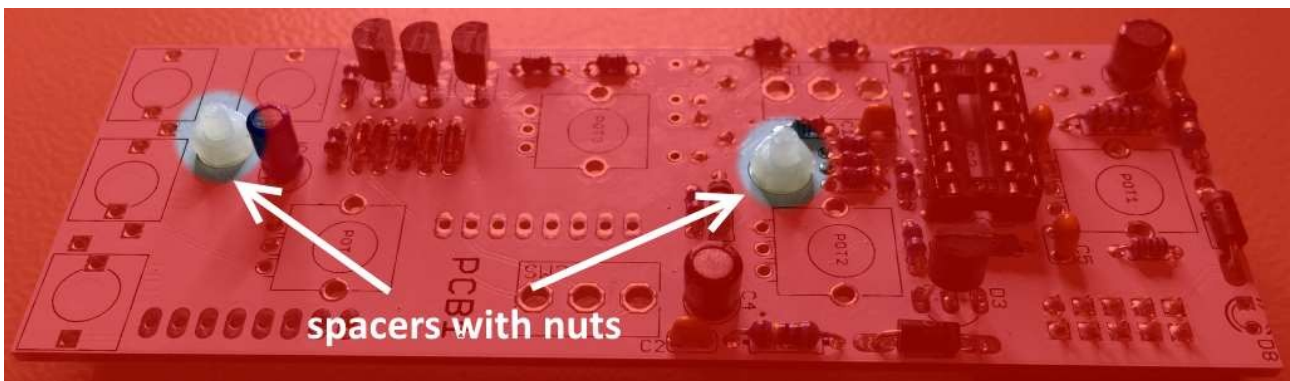
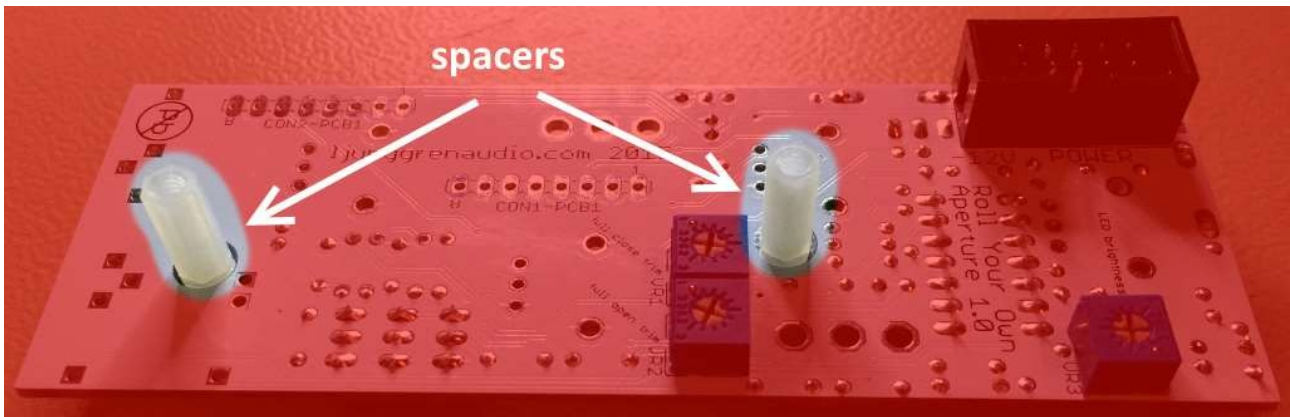

Step 24

Put the pin & socket strips into each other. Place them between PCB1 and PCB2 in their respective places. **Take a firm grip with a plier around the spacers and screw the screws into place like in the picture below.** It's important that the grip is firm as there is a bit of friction in this step and we don't want the nuts to loosen. If the nuts gets loose, tighten them again.

Only one of the screws need to be tight in this step, the other one can be screwed in just a little bit to provide orientation. Remove them again after the pin & socket strips are soldered.

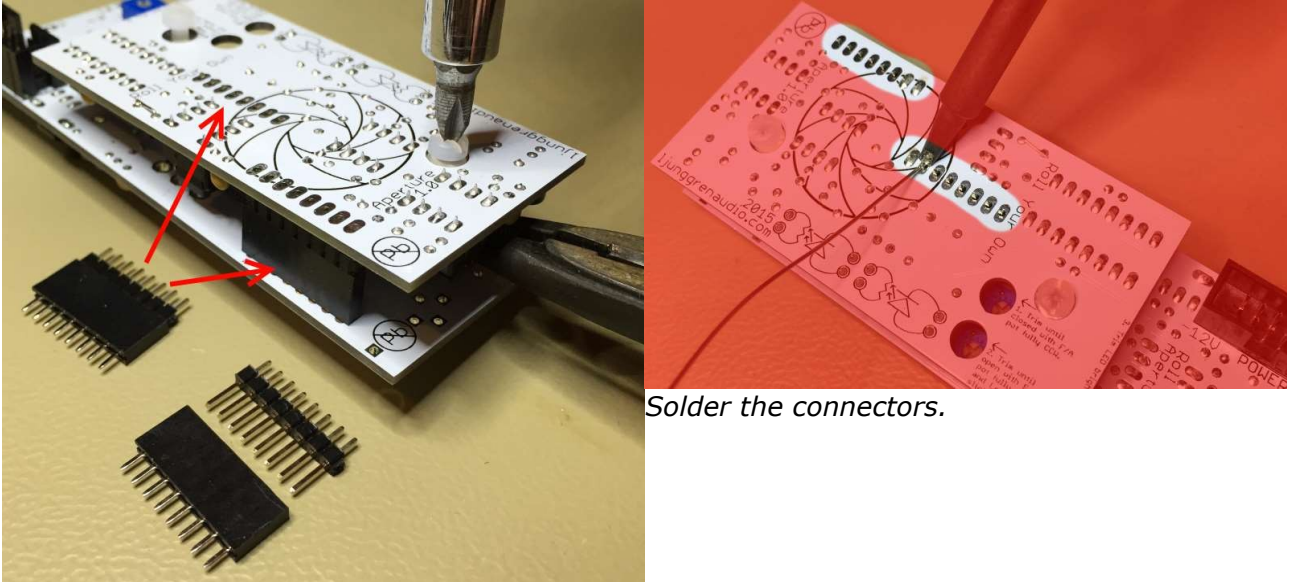

Solder the connectors.

You should end up with this.

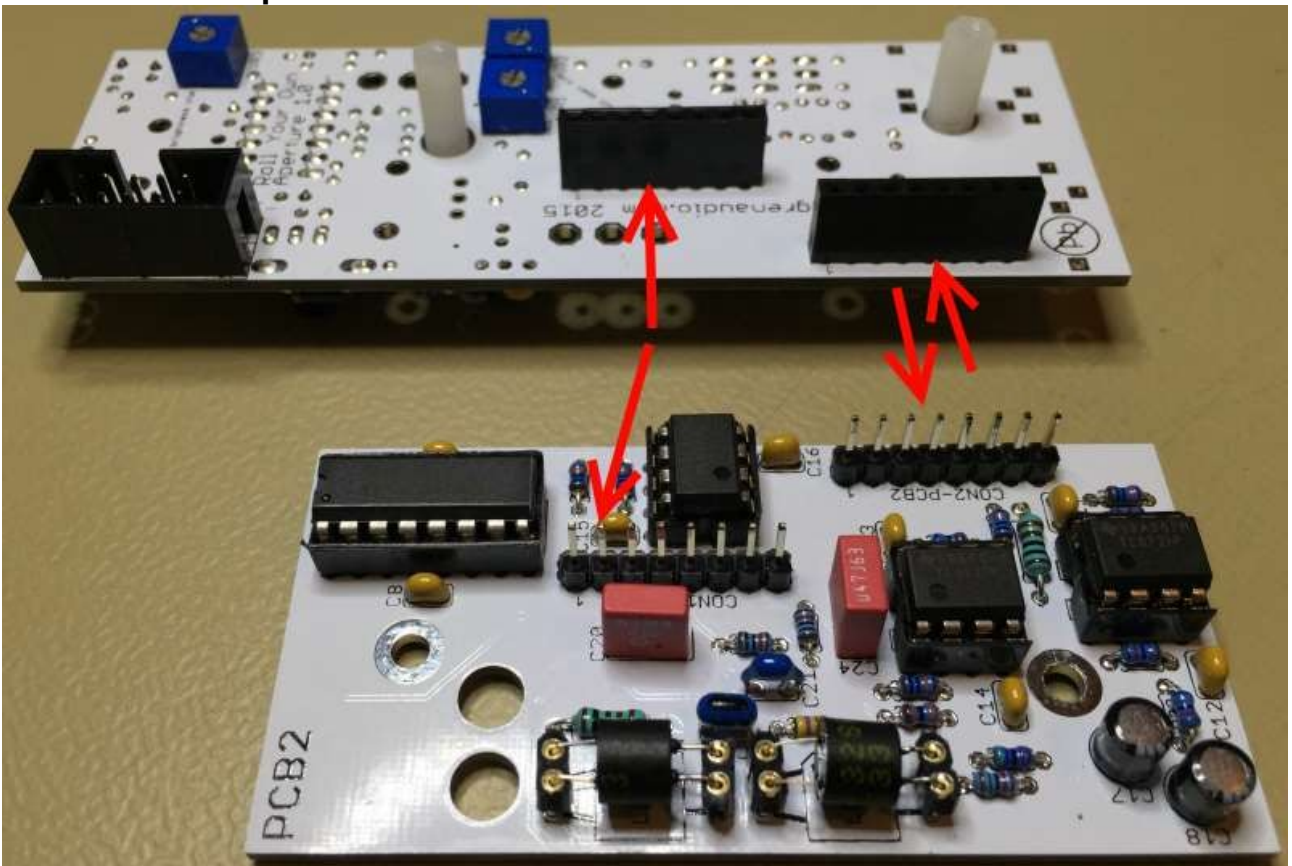

Step 25

Insert the IC in it's socket.

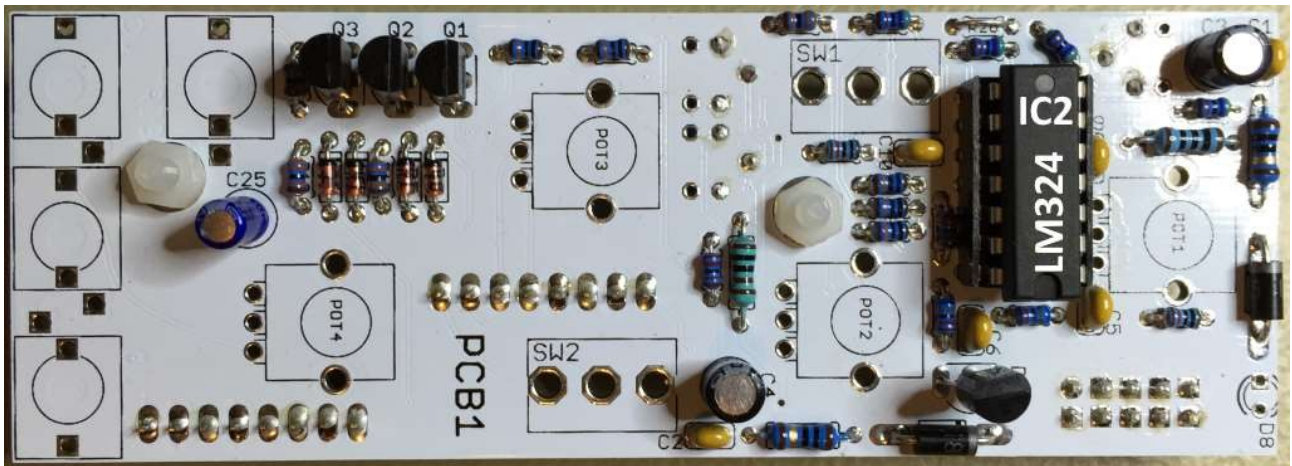

IC2 LM324

Step 26

Cut off the small metal tab sticking out on the potentiometers. Use a cheap plier/nipper for this step, save your expensive ones for other tasks. Mount 2 washers and 1 nut on each potentiometer. Make sure the nuts are tight.



Step 27

Place potentiometers, jacks, switches and LED in their positions but wait with soldering until the front panel is mounted.



You will need to bend the ground pins a little bit on some of the jacks.

The long pin of the LED goes into the hole with a square pad.

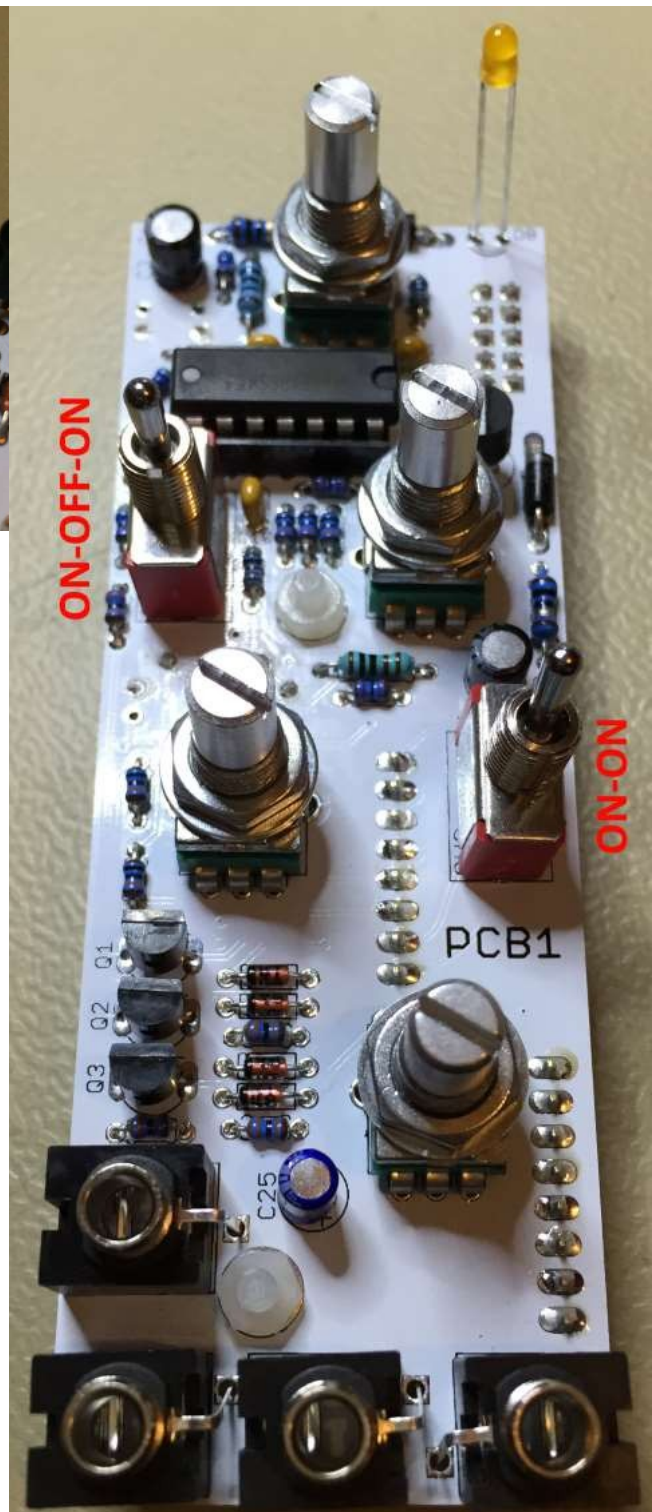

Step 28

Place the front panel on top and add 1 washer and 1 nut to each potentiometer, jack and the switch. Use a socket wrench to avoid scratching of the frontplate.

The switch have big pad holes to allow more different switches to fit but it also means you need to be extra careful to make sure the switch is aligned straight. The switches have their own nuts, Make sure to keep them separate from the jacks nuts as they look very similar and the switch nuts will fit on the jacks but the jack nuts won't fit on the switches.

Turn it upside down and make sure the LED go into the panel hole properly.



Now you solder all panel components in place.

Step 29

Now attach PCB2 to the module and screw the spacers together like in step 24. Remember the firm grip with the pliers.

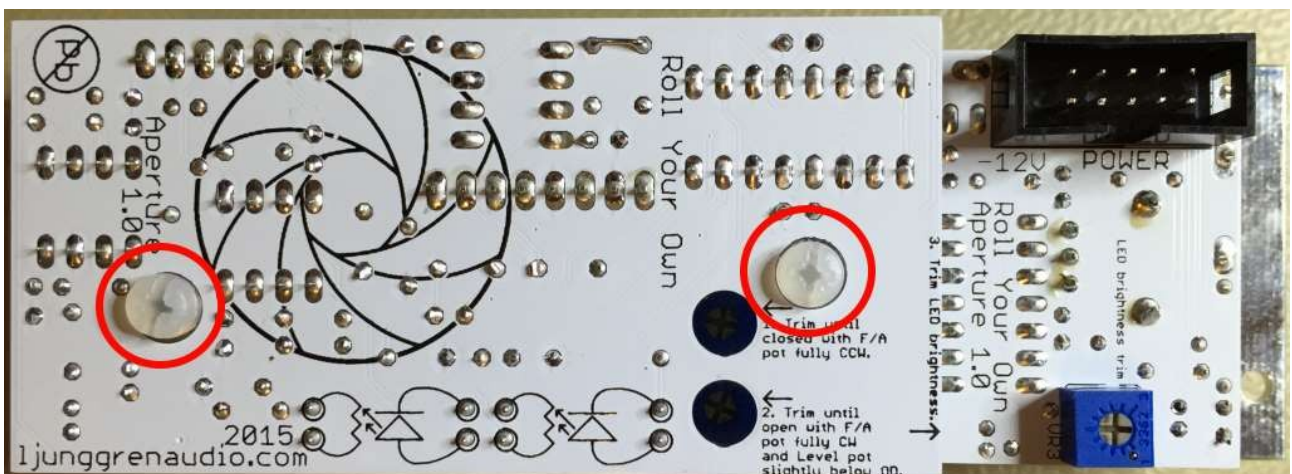
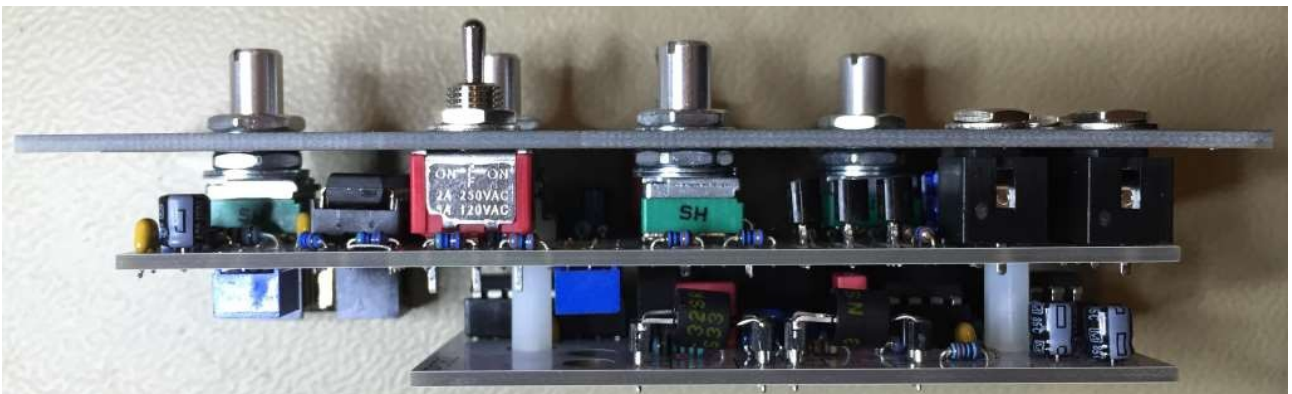

Step 30

Mount the knobs. The big red knob will touch the front panel so you need to make sure there is a tiny gap under it. You can accomplish this with a bit of **thick paper or envelope** and cut out an opening for the potentiometer shaft. Remember to have a slot in the side of the paper so it can be removed after the knob is attached.

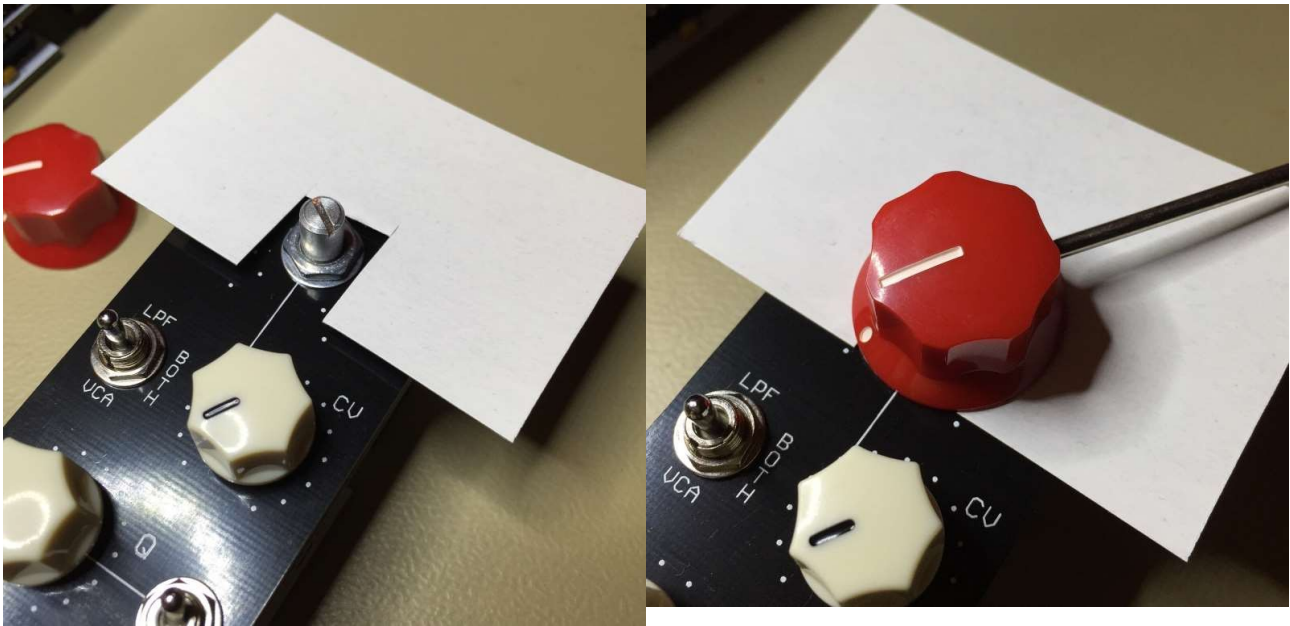

Now attach the power cable with the stripe indicating pin 1 on the -12V side.

Cablibration

Patch a 10Vpp sound to the audio in jack, like a normal VCO waveform.
Turn the level knob to slightly below overdrive (OD).
Don't patch the CV or Klang in.
Listen to the audio out.

1. Trimmer VR1

Switch the mode to VCA and turn off reconance/Q.
Turn the F/A knob to fully closed/counter clock wise.
Adjust the trimmer until sound no longer passes through.

2. Trimmer VR2

Turn the F/A knob to fully open/clock wise).
Switch between VCA and LPF modes repetedly to compare the signal while adjusting the trimmer. Adjust until you are happy with how much the filter opens compared to the VCA.

If you let the filter open fully then the output level will be a little higher than the input level. If you want a close match between input and output level, you need to measure the audio out with an oscilloscope.

Don't turn the trimmer all the way clock wise. You won't damage anything but the module won't work properly.

3. Trimmer VR3

Adjust the trimmer until the brightness of the LED is satisfactory with both F/A knob fully closed and fully open. The brighter the LED, the more current it will draw.

Finished module!

